

Laser Software Simplified Manual

Content

Part 1 Independent software.....	1
1.1 Software interface.....	1
1.2 Independent software installation.....	1
1.2.1 Laser installation	1
1.2.2 CorelDraw importing menu installation	7
1.2.3 AutoCAD importing menu installation	10
1.2.4 Illustrator importing menu installation	11
1.3 System settings	12
1.3.1 Machine management	12
1.3.2 IP/USB settings	19
1.4 Basic operation.....	25
1.4.1 Graphics array.....	25
1.4.2 Nesting	28
1.4.3 Data processing	28
1.4.4 Starting point setting.....	35
1.4.5 Display.....	36
1.4.6 Bmp Processing.....	37
1.4.7 Group	38
1.5 Output processing	39
1.5.1 Layer parameter.....	39
1.5.2 Route optimization	45
1.5.3 Work pre-treatment	47
1.5.4 Output processing.....	49
1.5.5 Manual control.....	50
1.6 Case application.....	50
1.6.1 General output processing.....	50
1.6.2 Curve smoothing	54
1.6.3 Intelligent double shift processing.....	55
1.6.4 Feed processing.....	55
1.6.5 Large file segmentation processing	56
1.6.6 Device type.....	57
Part 2 Panel operation instructions.....	59
2.1 Introduction.....	59
2.1.1 Operation panel.....	59
2.1.2 Key functions introduction.....	59
2.2 Main interface introduction	61
2.2.1 Starting up interface	61
2.2.2 Standby interface	61
2.2.3 Speed setting interface	63
2.2.4 Light intensity settings interface.....	63
2.2.5 Frame preview interface	64

2.2.6 File selection interface	64
2.2.7 File setting	65
Part 3 Projection cutting.....	67
3.1 Installation.....	67
3.2 Calibration	68
3.3 Project setting.....	71
Part 4 Appendix.....	72
TL - 403C wiring diagram	72
TL - 410C wiring diagram	73
Installation dimension	73
TL-410C Axis Z/U/V multiplexing and status signal Output	77
Common and special function	77
Common problems	78

Part 1 Independent software

Installation requirements: All of the following software is installed in 32 bits Windows 7 system, while 64 bits system is also supported by our software. Installation method of 64 bits system is the same as that of 32 bits system. When using CorelDraw and CAD software, please use officially full edition to avoid any failure of plug-in installation due to software edition or any other reasons.

1.1 Software interface

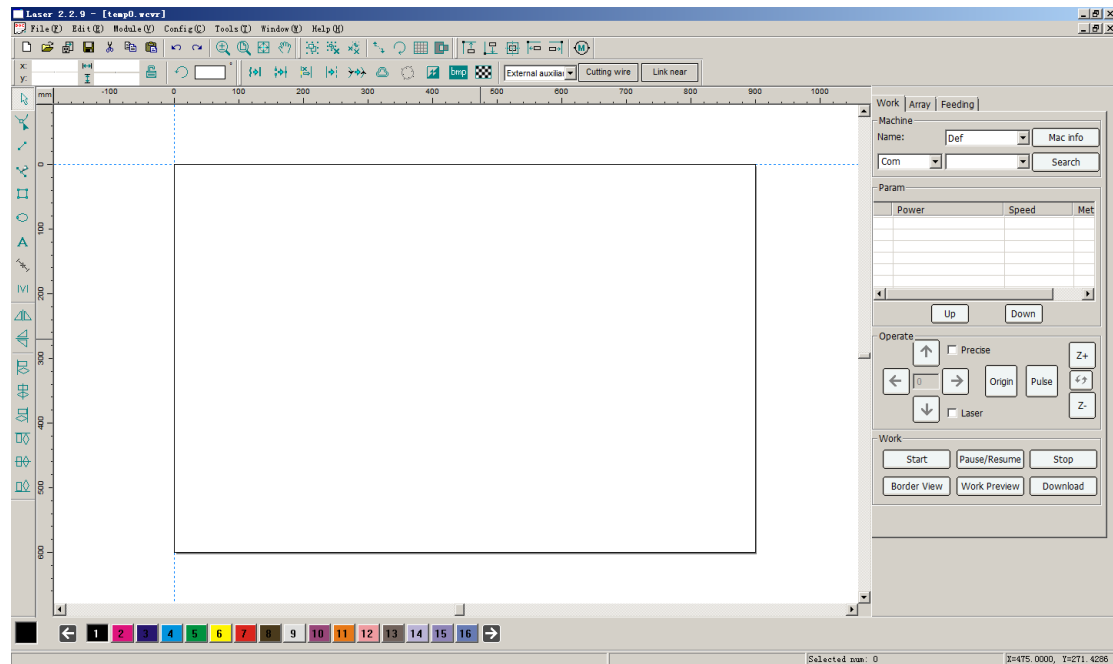

1.2 Independent software installation

1.2.1 Laser installation

- 1) Double click operation box [Laser V X.X.X.exe] (X.X.X is edition No.)

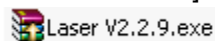

- 2) Files are decompressed automatically and started to be installed. Then select a language and the software will choose a default language such as Simplified Chinese, Chinese Traditional characters or English version according to the language of operation system.
- 3) Product installation path is installed by default in Disk C. If you want to install it into other disks, please click "Path" option in the option for the product catalogs, select the drive you want to install and then click confirm.

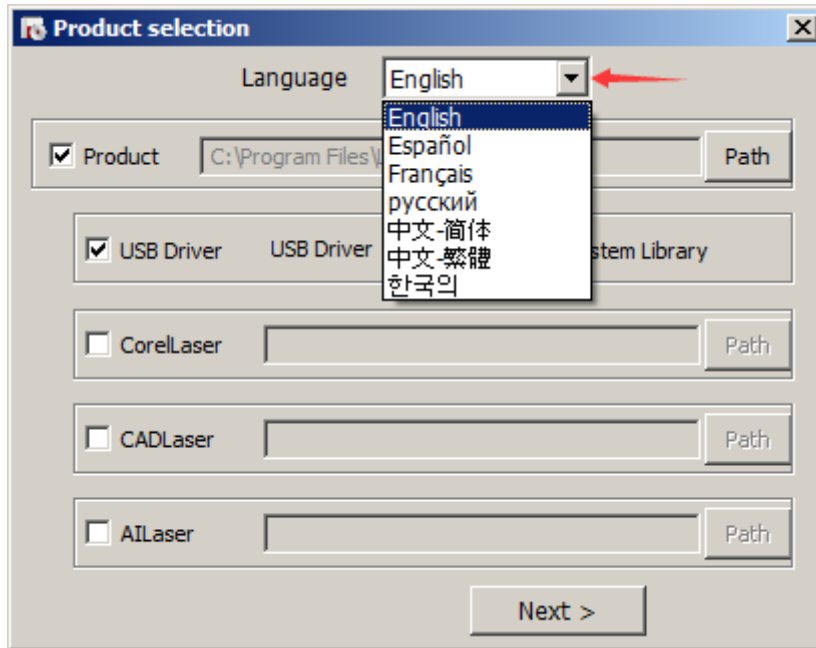

- 4) For the first time to install our software, it is checked by default which program is the user must install, Laser software, USB Driver and System Library.

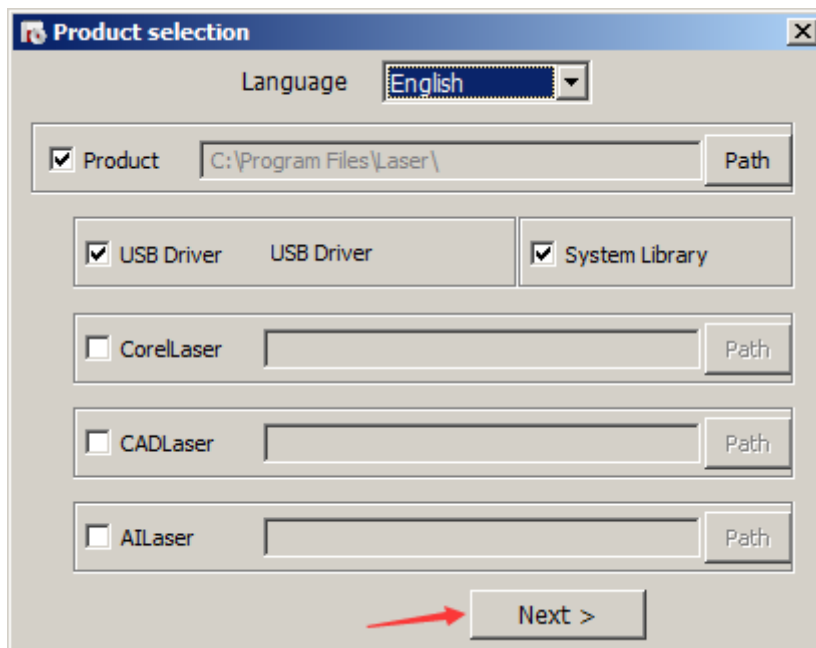

- 5) Click [Next] to continue.
- 6) Click [Installation] to execute installation of Laser and USB driver.
- 7) Independent software supports software such as CorelDraw, CAD, AI among others, if these products are required to be used with the Laser software, please click appropriate importing plugs-in to install.

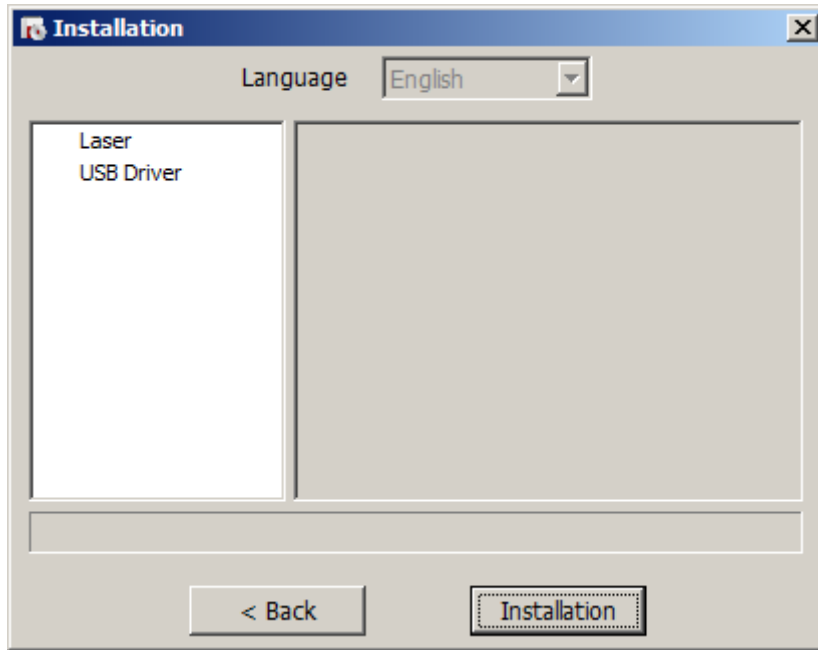

Installing USB Drive...

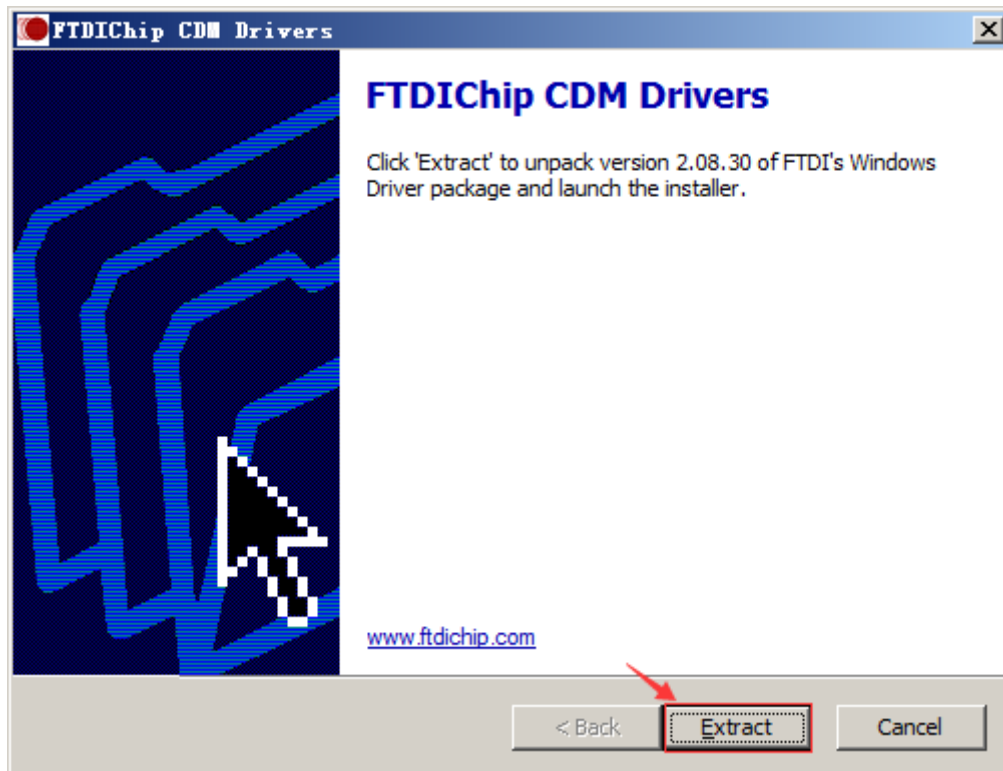

- 8) Click [Extract].

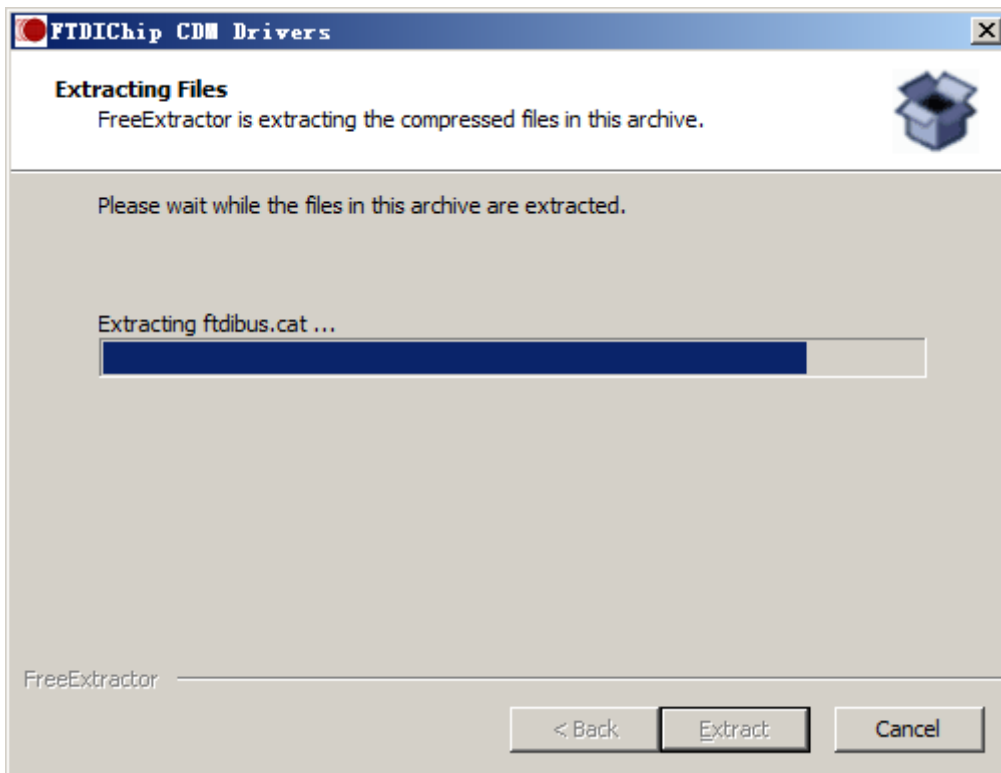

- 9) Click [Next] to continue.

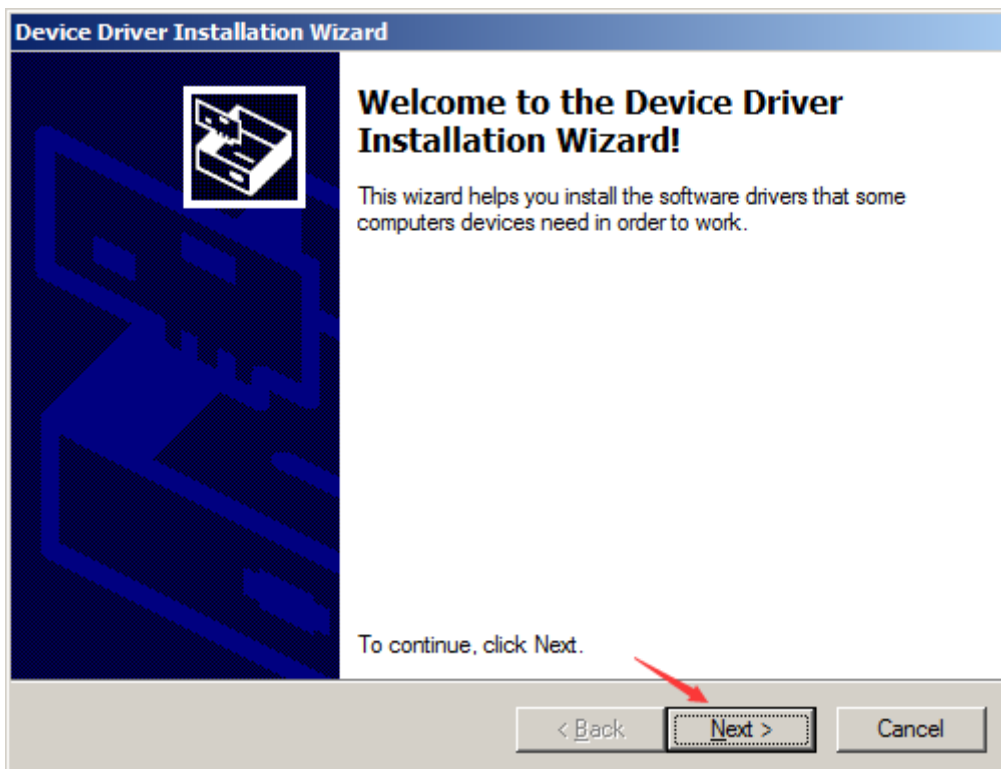

10) Click [Finish] and USB driver installation is completed.

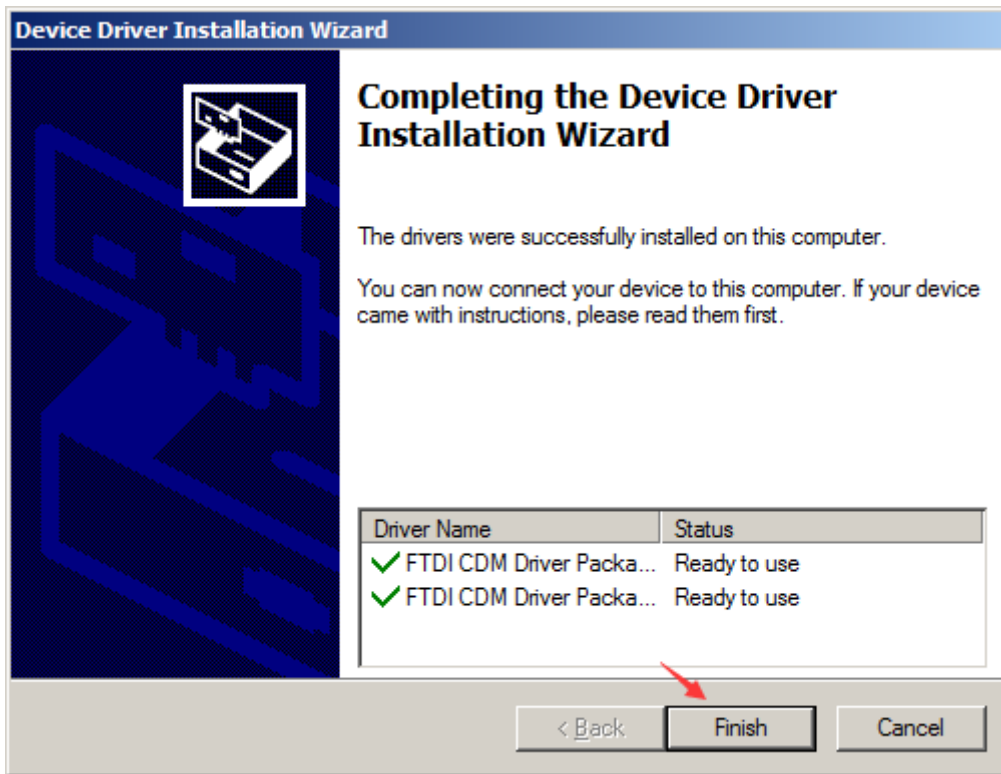

11) Now it is displayed a dialog for system library installation.

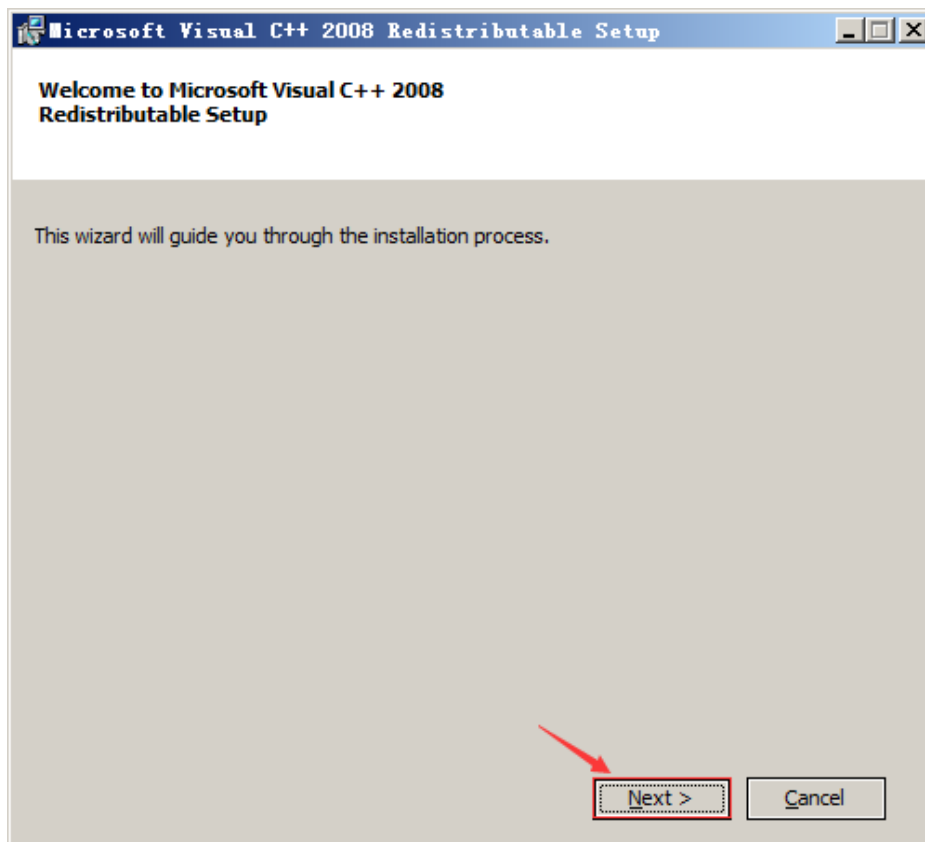

12) Click [Next] to continue.

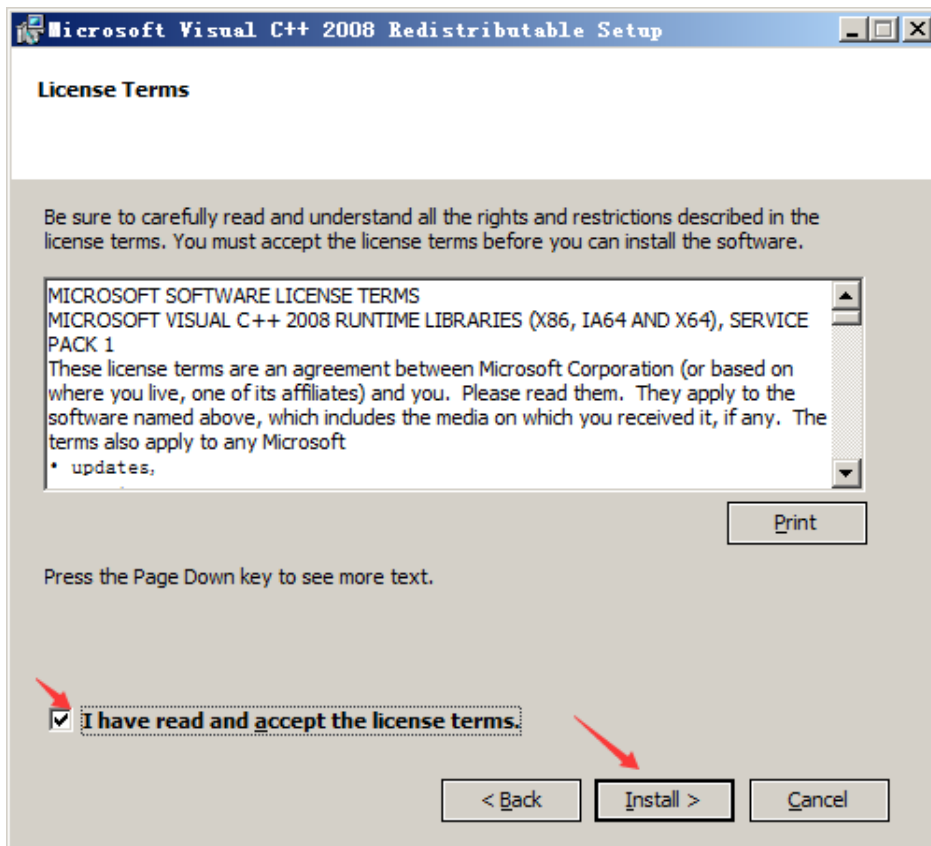

13) Check the “I have read and accept the license terms” button and click [Install] to continue.

14) Click [Finish] button for completing installation of system library for laser software.

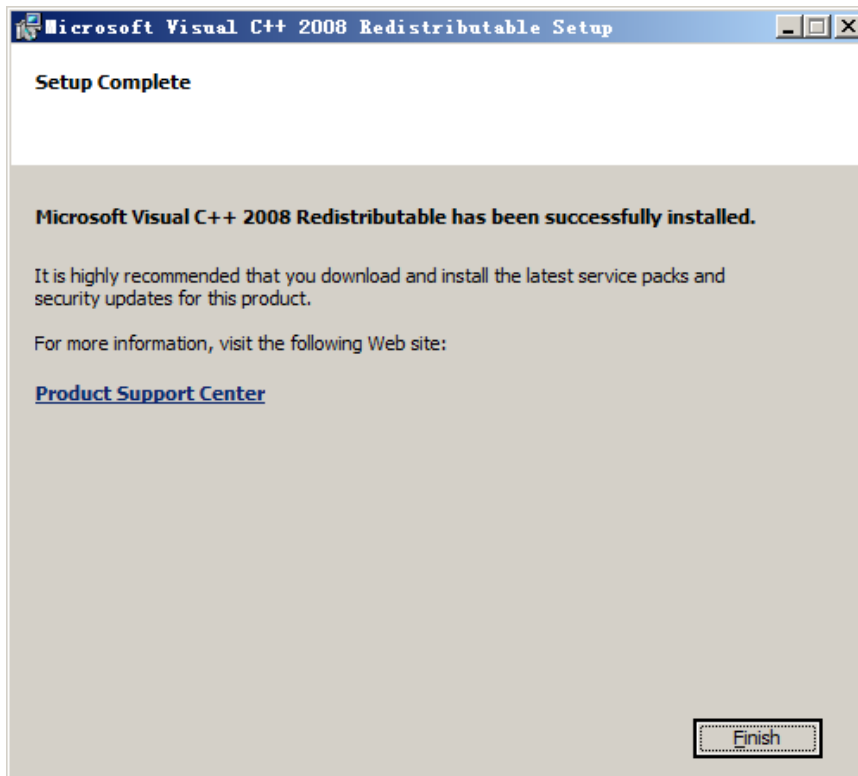

15) Click [Finish] button for installing completion.

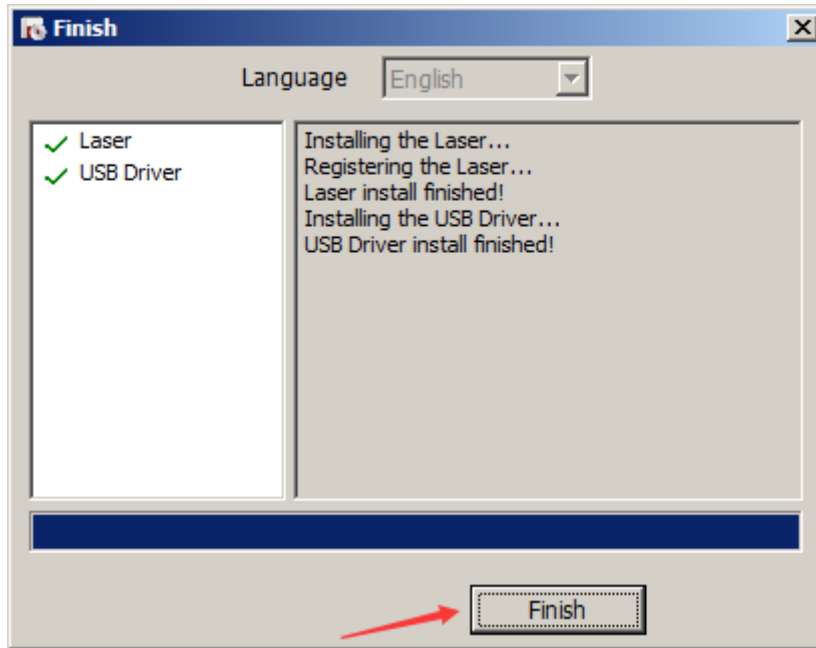

1.2.2 CorelDraw importing menu installation

Note: Our present CorelDRAW importing menu supports versions of CorelDRAW 12 to CorelDRAW X7 of 32 bits and 64bits.

Take the CorelDRAW X7 as an example.

Installation method for CorelDraw importing menu is the same as that of “laser” for the first time, users only need to

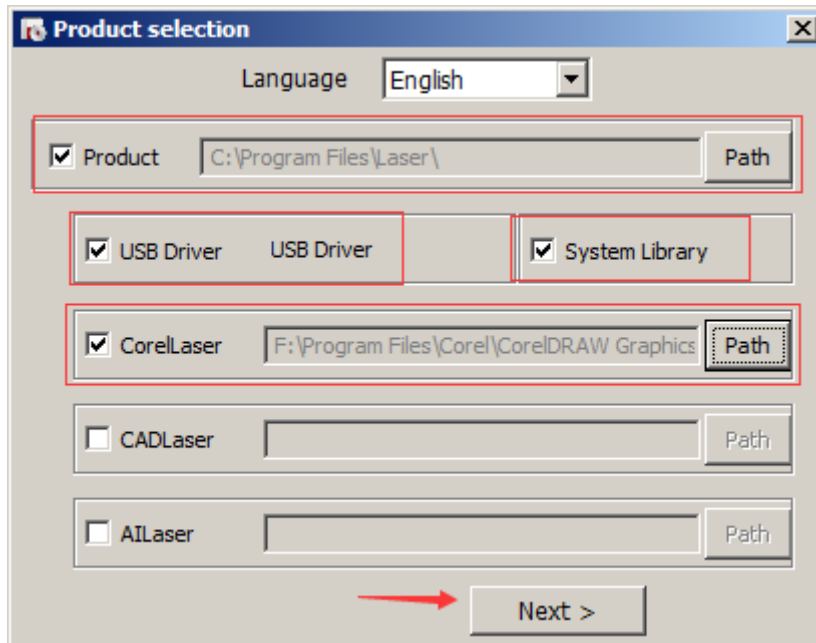

- 1) Click [Product].
- 2) Click [USB Driver].
- 3) Click [CorelLaser].

4) Click [Next] → [Installation] → [Finish].

If CorelDRAW main menu won't display menu button after installation, the following procedures should be followed:

1) Start CorelDRAW X7.

2) Click menu list: [Tool] → [Macro] → [Run Macro] and “Run Macro” dialogue would pop up.

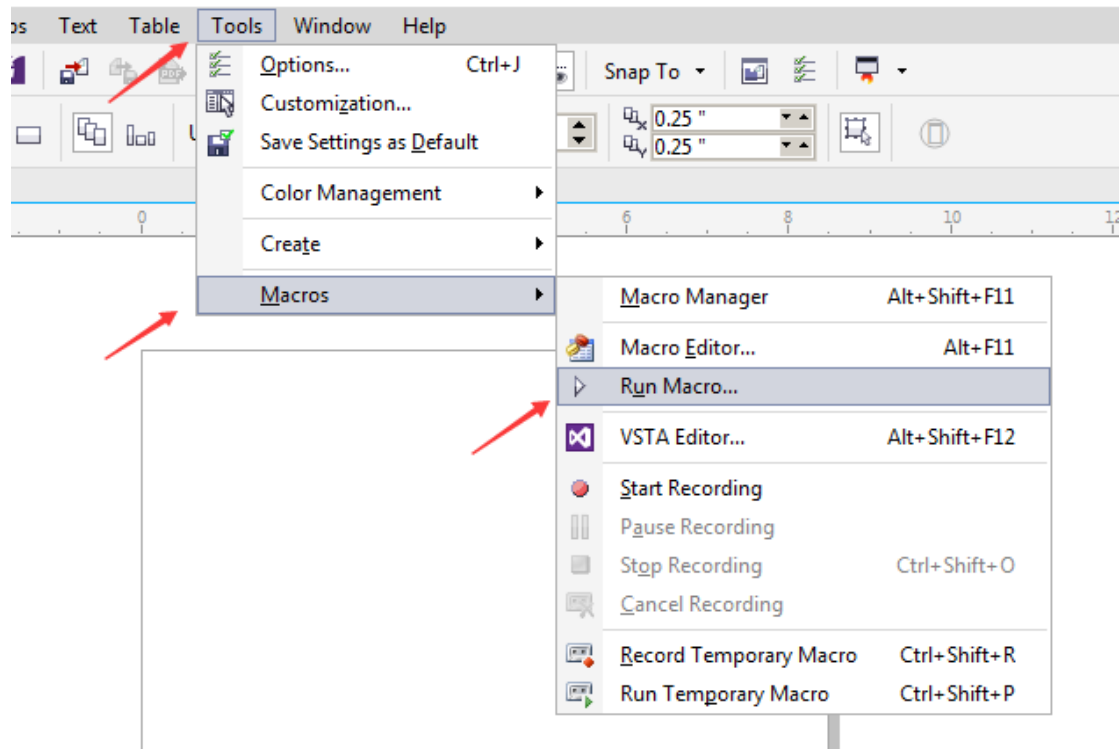

3) Select “JGDK(JGDK.GMS)” in the drop-down list of “Run Macro” dialogue box.

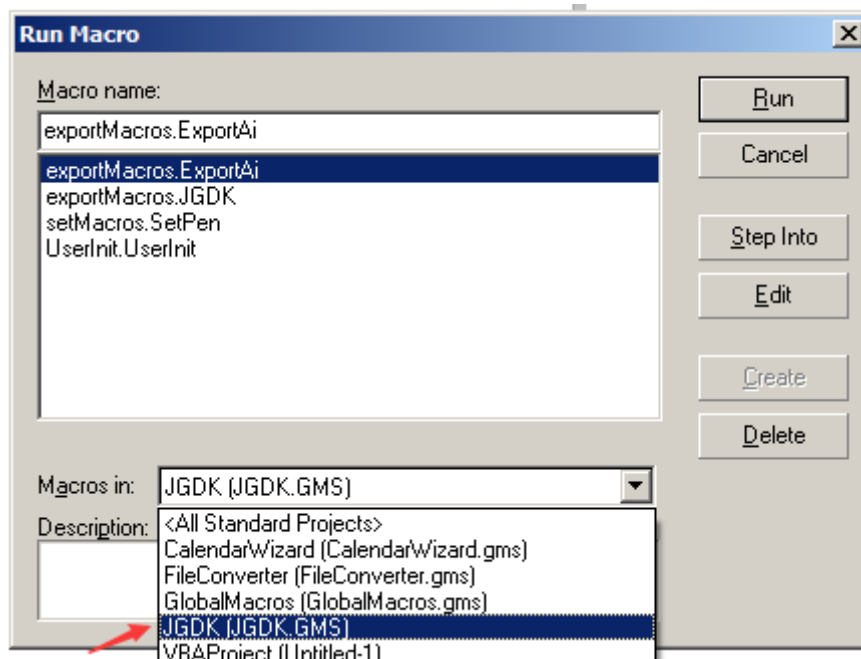

1.2.3 AutoCAD importing menu installation

Note: At present our AutoCAD importing menu supports versions from AutoCAD 2004 to AutoCAD 2014 of 32 bits and 64bits.

Take AutoCAD 2013 as an example.

Installation method is the same as that of Laser for the first time. Users only need to do the following steps:

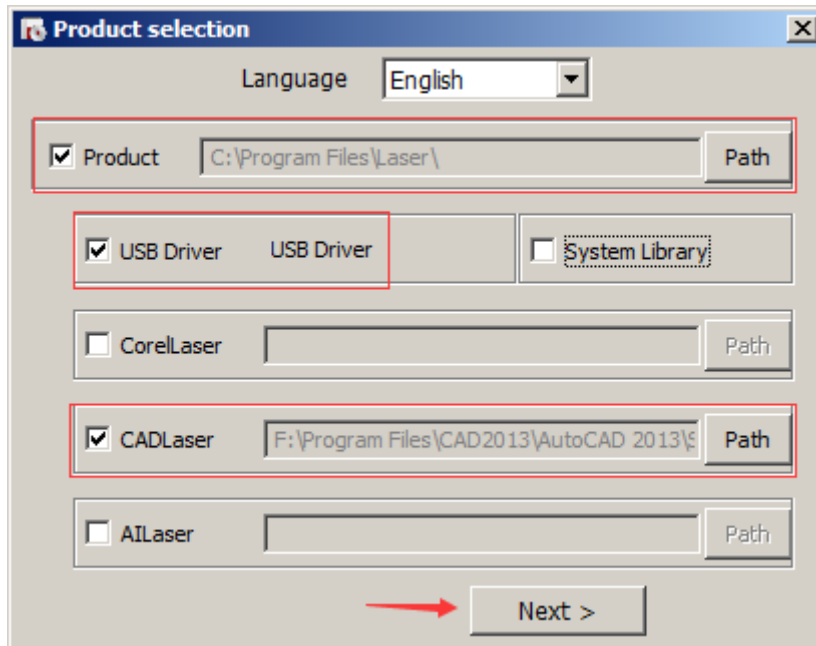

- 1) Click [Product].
- 2) Click [USB Driver].
- 3) Click [CAD Laser].
- 4) Click [Next] → [Installation] → [Finish].
- 5) After installation is completed, open AutoCAD 2013 and change to the classical mode. The [CAD Laser (C)] will appear behind the menu bar, indicating installation was successfully completed as shown in the figure below:

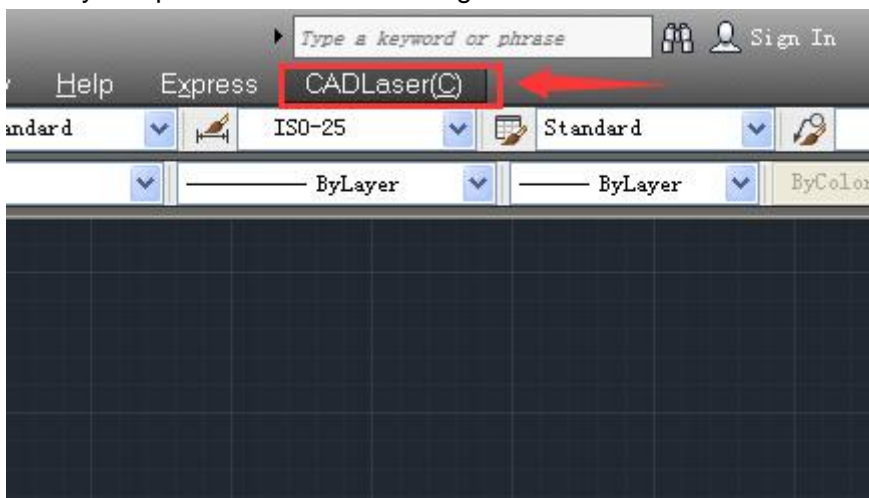

1.2.4 Illustrator importing menu installation

Note: At present our Illustrator importing menu supports versions from AI CS2 to AI CC of 32 bits and 64 bits! (The CC version of AI includes 32-bit and 64-bit version, although only 32-bit version was provided before, our software actually supports both versions.

Take AI CS5 as an example.

The installation method of this importing menu is the same as that of Laser for the first time. Users only need to do the following steps:

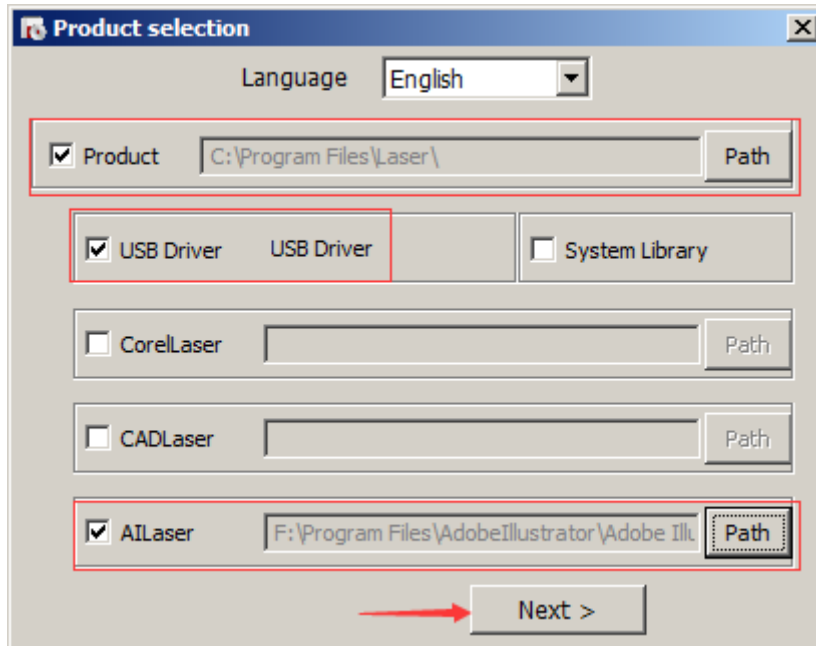

- 1) Click [Product].
- 2) Click [USB Driver].
- 3) Click [AI Laser].
- 4) Click [Next] → [Installation] → [Finish].
- 5) Open AI and select “Laser Design → Export”, it would appear in the menu bar box. Such words indicate that installation is successfully completed as shown in the following figure.

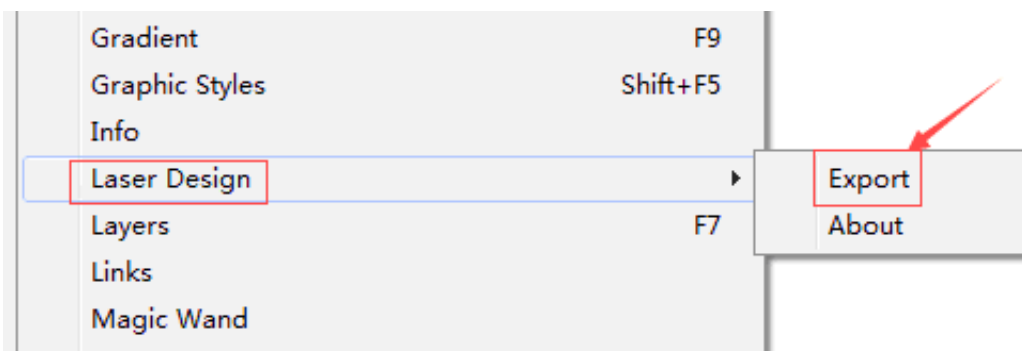

Note: If it is the second time for all importing menu of the above-mentioned software to be installed, there is no need to click [Product] or [USB Driver] and [System Library].

1.3 System settings

1.3.1 Machine management

Open Laser software as shown in the following fig., and then click the [Machine information] button on the working area of the right side.

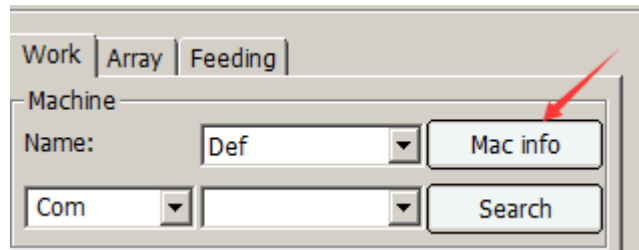

The setting related to machine includes machine breadth, technological parameters and machine parameters.

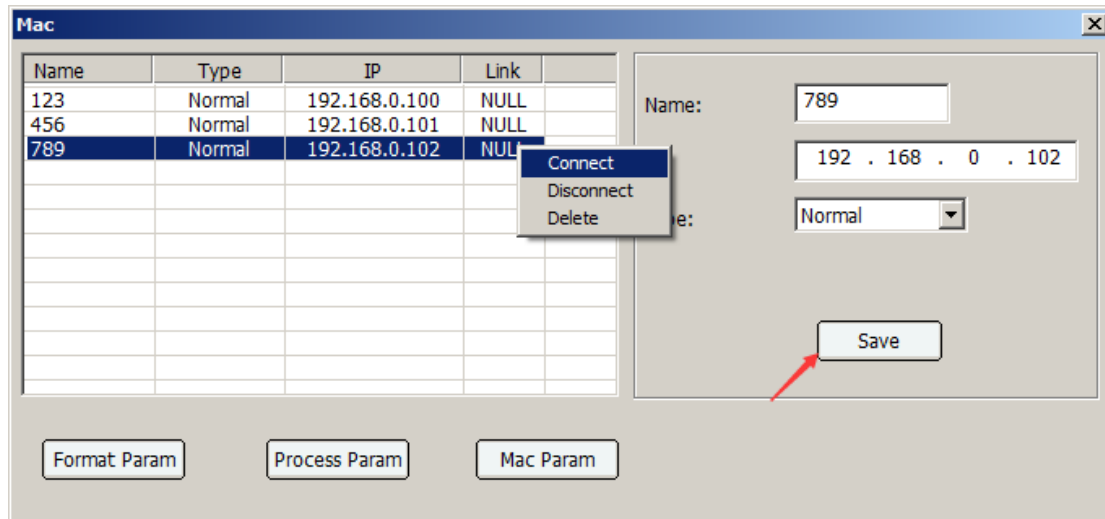

[Name]: Different devices may have the same IP address, so devices are named for the convenience of identification. Each name is sole in one copy of device management table.

[Type]: If the device is not equipped with camera related equipment, it should be classified as normal type. Device of CCD camera should be classified as camera type.

[IP]: IP address must agree with that shown on the device, otherwise laser software can't be connected to the device (refer to IP settings).

[Save]: Click records in the selection list and the selected record information will appear in the right side edit box. The [Name] from the list is the only mark for identification. If device name is the same as some record in the list, click [Save] button to modify the records in the list. If the device name does not exist in the list, click [Save] button to add a new record.

[Delete / add]: Device management table is a roster of all devices. If a device is no longer used, select it in the form and right click to open the menu, and then click [Delete] to delete. If a new machine is purchased, users can edit its name, IP address and device type in device information in edit column on the right side, and then click [Save] below to

add it to the list.

1.3.1.1 Breadth parameter

Select the machine name whose breadth size needs to be modified, and click **[Format Param]** to open the breadth parameter dialogue box. As shown in the fig. below:

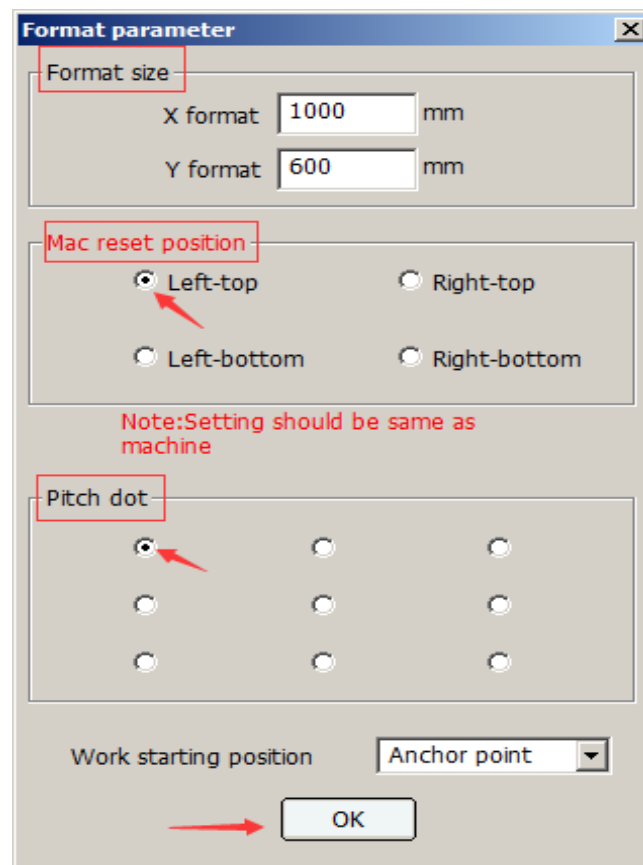
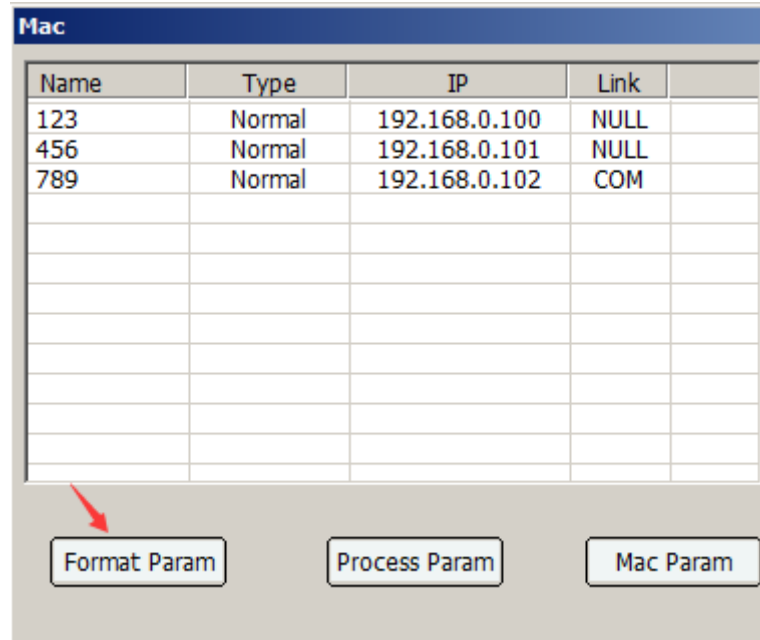

[Machine reset position]: Refers to the point where laser head returns after the machine

is powered on or the "Reset" button of the machine is pressed. One of the points on left-top, left-bottom, right-top and right-bottom position could be set as machine reset point, and the parameters of such point should be in line with the installation of the machine.

[X format]: Refers to the maximum distance within which laser head can be moved in X axis direction starting from the machine reset point (namely machine original point). If the distance is bigger than the actual distance machine can be moved in X axis, laser head will crash.

[Y format]: Refers to the maximum distance laser head can be moved in Y axis direction starting from the machine reset point (namely machine original point). If the distance is bigger than the actual distance machine can be moved in Y axis, laser head will crash.

[Pitch dot]: Refers to position of the graphics relative to the starting point (Pitch Dot). For example select the left-top in the below figure, then the starting point of the cutting graphics is left-top.

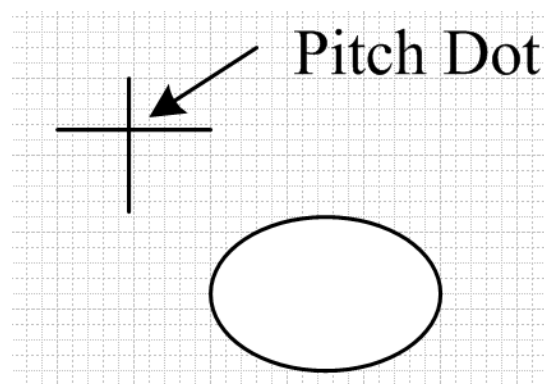

1.3.1.2 Technological parameters

Select machine, click **[Process Param]** and access into processing parameter settings, as shown in figure below.

[Use]: The corresponding processing is launched.

[Add]: Add the corresponding processing parameters.

[Del]: Delete the corresponding processing parameters.

[Save]: Save all processing parameters in the parameter list.

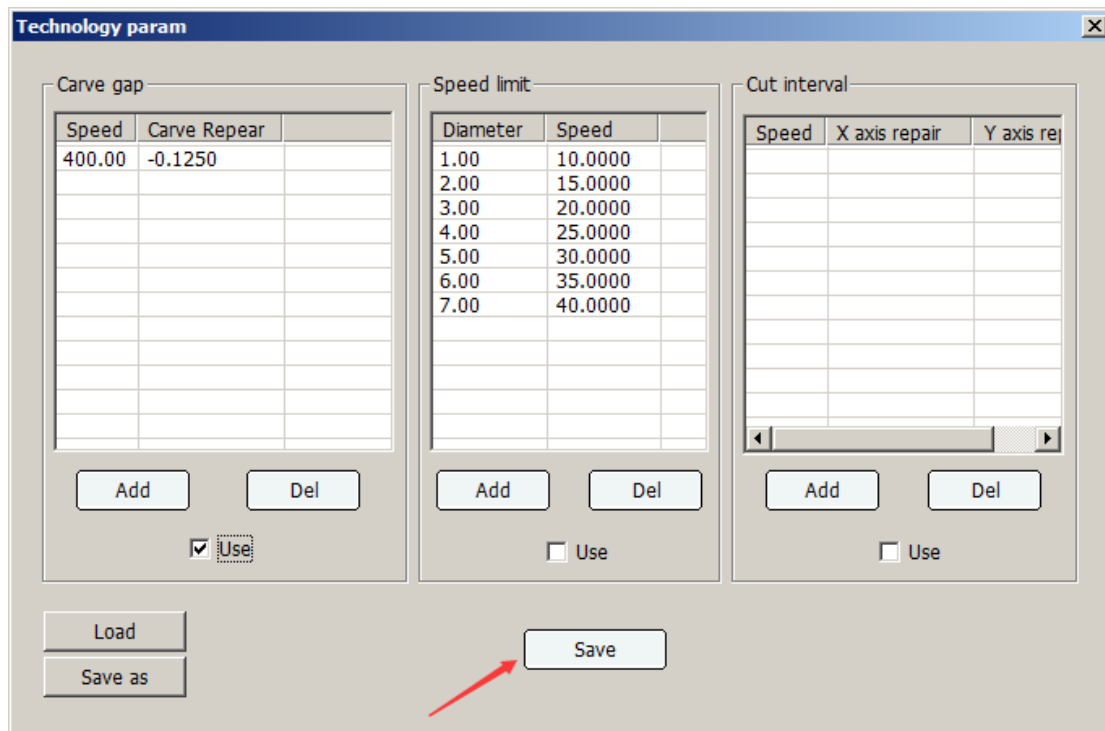

1.3.1.2.1 Carving clearance

The different precision of machine would cause clearance error in the process of engraving from both horizontal sides. The clearance error in the inverse movement would cause double or vague image of carving effect. The software has carving clearance compensation function which can remove various clearances caused by model differences as shown in the table below:

[Use]: Click [Use] check box under the list and carving clearance compensation function is launched.

[Add]: Click [Add] button and parameter editing dialog box will pop up. After editing parameters, click [OK] to add a new item.

[Del]: Select the record to be deleted in the list, and click [Del] button below.

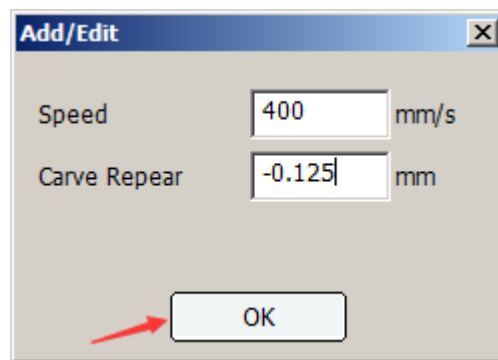
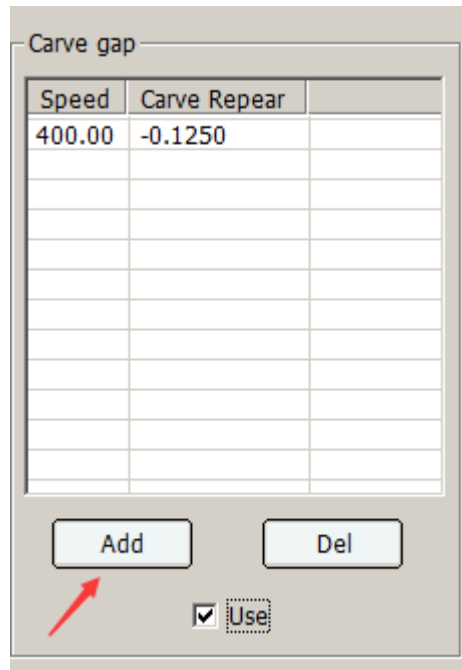

Test method:

- Set the compensation value corresponding to engraving speed to 0;
- Clearance compensation testing process: make three 20 x 10 rectangles with interval length of 5mm. Set work for carving mode and carving precision scale to 1mm, and then output work.



- An ideal graphic is below.

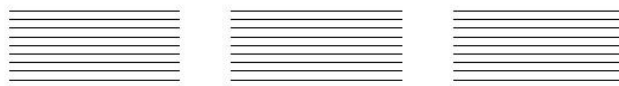

- If an ideal effect is achieved, compensation process, test or using of carving clearance parameters are not necessary.
- Possible actual carving results is below

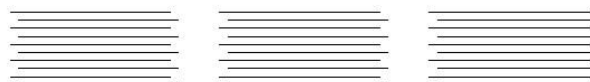

- Intermediate compensation which is used to align carving line in the middle is generally negative value and likely to be positive value depending on carving machine. And negative and positive value compensated with clearance value is also the compensation value for adjusting obverse and reverse direction. Positive and negative compensation value depends on the model of the machine. Generally speaking, the compensation value is first set to 0 so that the carving effect could be pre-viewed, and then set a big compensation value such as 3 mm is to preview sculpture effect, thus whether the compensation value is positive or negative would be known.

1.3.1.2.2 The speed limit of small graphic

The same graphic processed by different models, belts, pulleys and motor types may produce different effect even at the same speed. This is an objective factor influencing machine processing course. To solve this problem, the software provides a speed limit list targeted for different models to record the highest speed at which the machine can run in circles of different sizes (in the precondition of guaranteeing the effect), as shown in the follow fig

[Use]: The [Use] option below the list allows users to decide whether to use speed limitation function.

[Add]: Click [Add] button and parameter editing dialog box would pop up. After editing parameters is completed, click [OK] to add a new item.

[Del]: Select the record to be deleted in the list, and click [Del] button.

Diameter	Speed
1.00	10.0000
2.00	15.0000
3.00	20.0000
4.00	25.0000
5.00	30.0000
6.00	35.0000
7.00	40.0000

Use

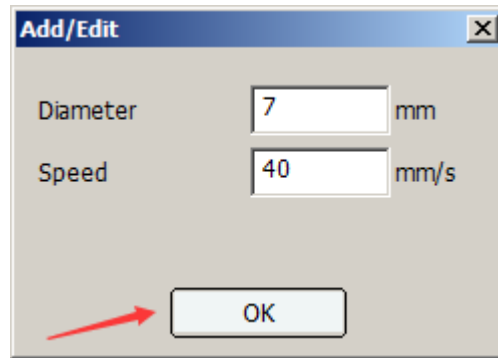

1.3.1.2.3 Cutting clearance

If the following processing effect appears, cutting clearance function could be launched.

[Use]: The [Use] option of the list offer users options for deciding whether to use speed limitation function.

[Add]: Click [Add] button and parameter editing dialog box would pop up.

[Del]: Select the record to be deleted in the list, and click [Del] button.

After editing parameters, click [OK] to add a new item.

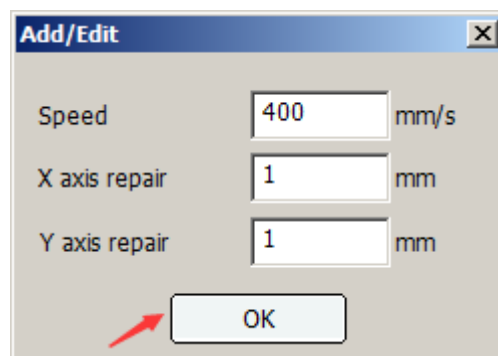
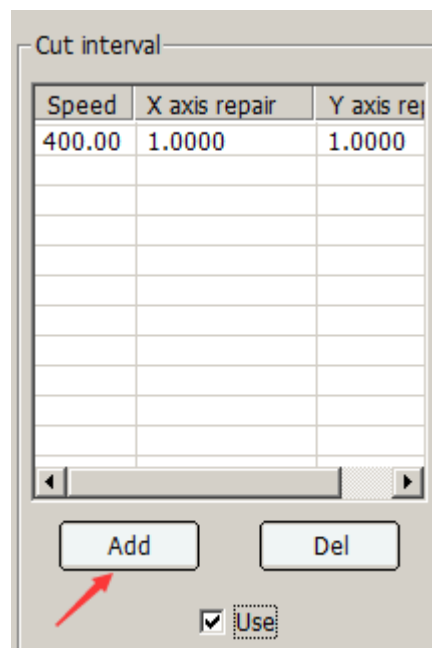

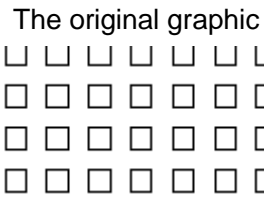
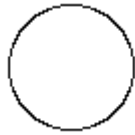

The original graphic

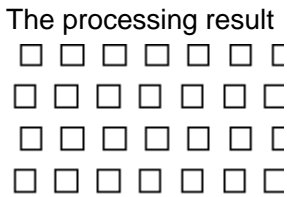
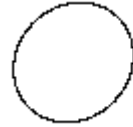

The processing result

1.3.1.2.4 Load/Save parameters

When finish adding technological parameters, it is able to save the parameters file by “Save as” button. And when reinstalls the system, it is able to load the previous parameters file to the laser software by “Load” button.

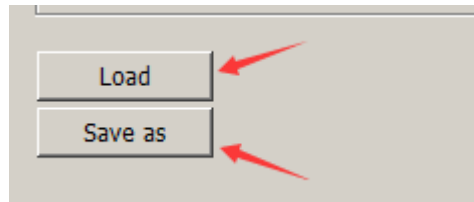

1.3.2 IP/USB settings

As shown in fig. below, on the upper right part of software interface device information is displayed. Laser software will communicate with machine through network or USB cable during the process of downloading graphics file, read-writing machine parameters, and executing online control. IP address is setting for network, and Com port Number is setting for USB. The priority of network is higher than that of USB. In the presence of both communication types, laser software will give preference to network communication.

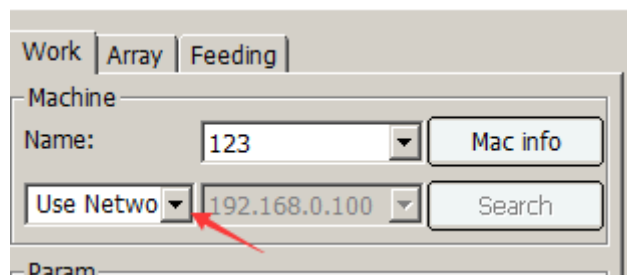

1.3.2.1 Network communication

In the machine information setting dialog, set the IP the same as that in the machine main-board. Then set the first three sections of IP in the computer to the same address value, and the last section to a different address. For instance if the machine IP is 192.168.0.100, record the IP 192.168.0.100 for the selecting machine in Laser software. And set the computer IP to 192.168.0.2, thus network transmission can be conducted.

1. Windows 7 IP Settings

- 1) Open "computer", click "Open Control Panel".

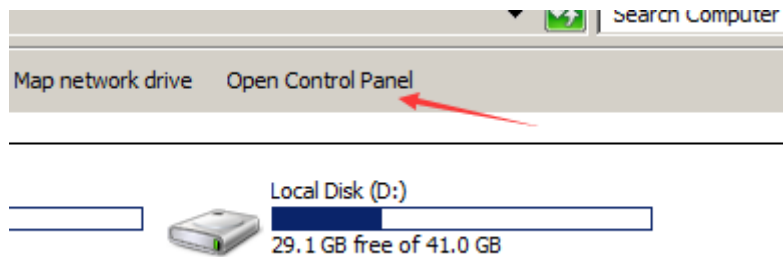

2) Select "View network status and tasks" under "Network and Internet".

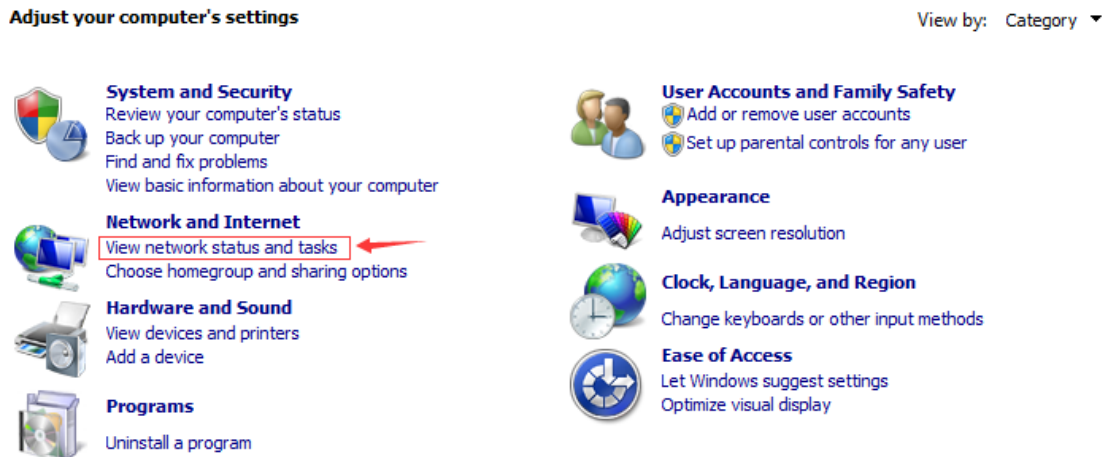

3) Click "Change adapter settings".

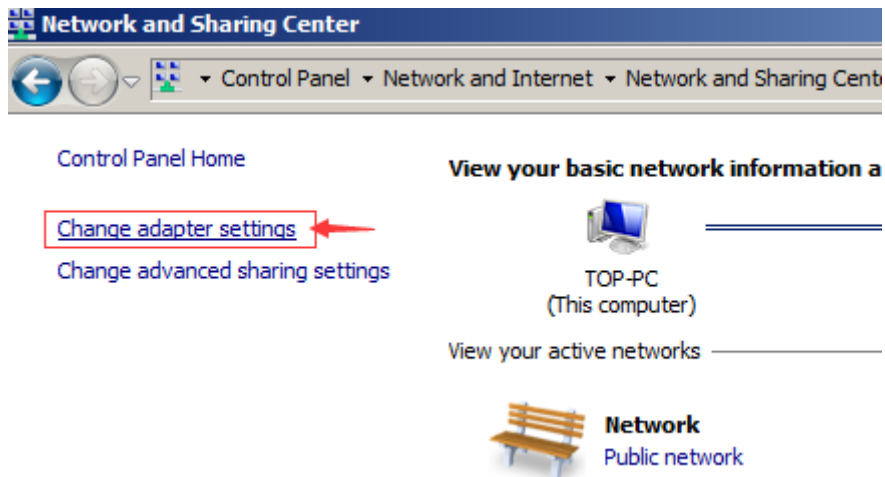

4) Select "Local Area Connection" and click right key to pop up "Properties" option. And then the "Local Area Connection properties" dialog box would appear. Double-click "Internet protocol version TCP/IPv4" and conduct setting parameters.

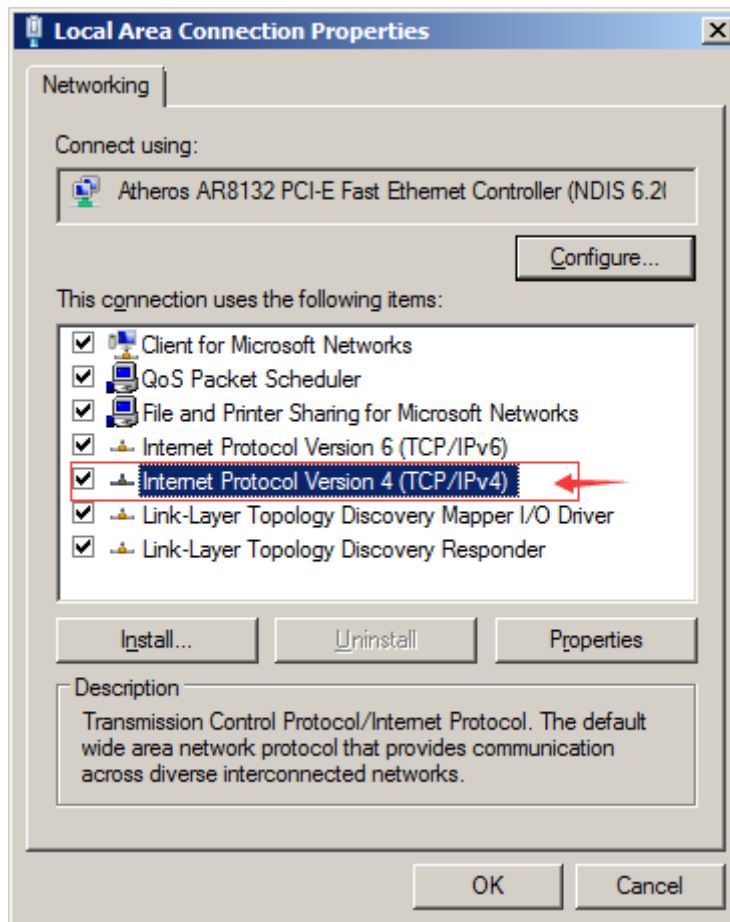
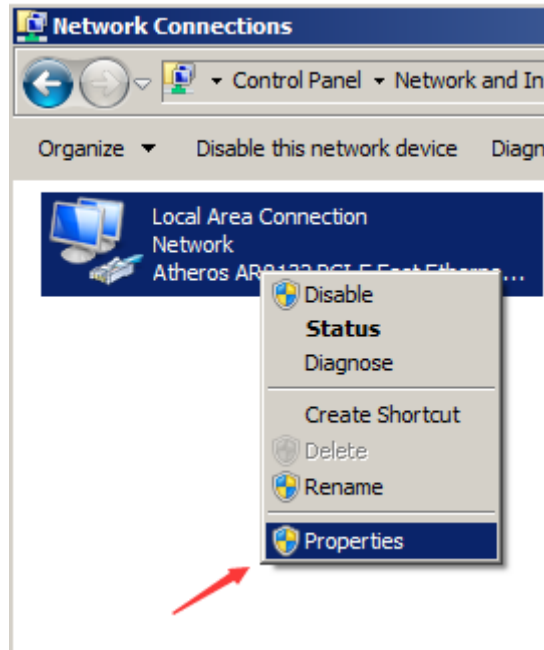

- 5) Select "Use the following IP address", input IP address, subnet mask code, and default gateway, as shown in fig. below.

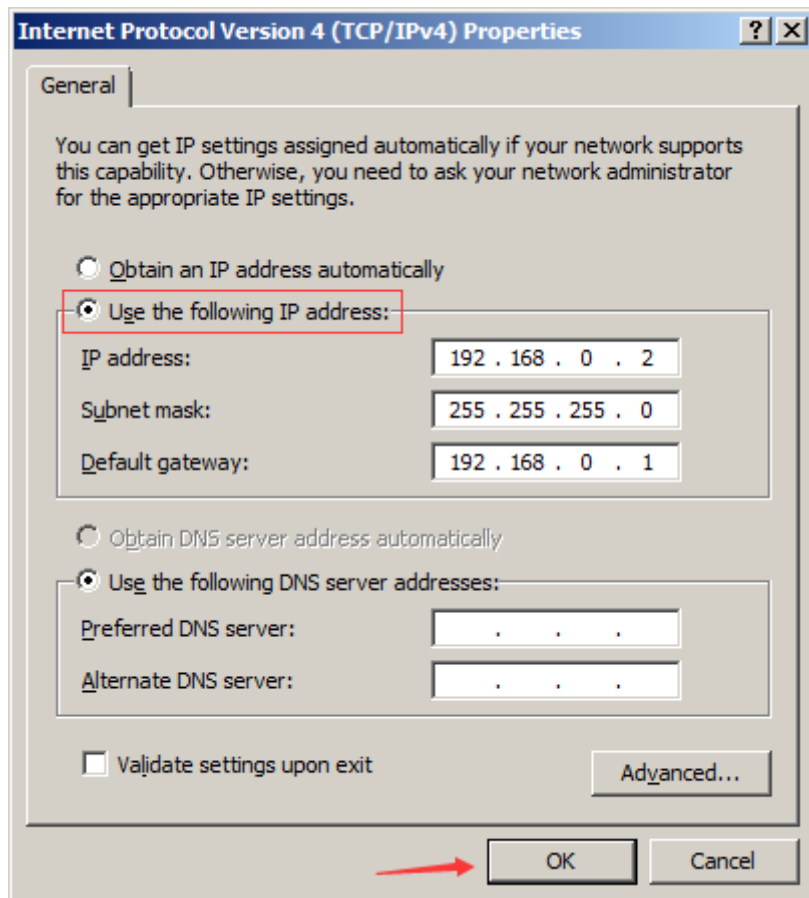

After the above steps, click [OK] and the computer IP address setting is accomplished.

1.3.2.2 USB communication port settings

After the system reset of control card is completed, connect the computer with USB cable, the computer will automatically allocate a COM port for communication. But when the allocated COM port Number is larger than that of the COM9, communication would be interrupted, and users have to manually change the port number. The port number changed should be between COM3 ~ COM9. Then check the COM port allocated by the computer.

1. View the COM number. Select "Computer" and click the right key of the mouse to select "Device manager", click the port (COM and LPT), the "USB Serial Port (COM3)" is the port Number allocated by the computer! As shown below:

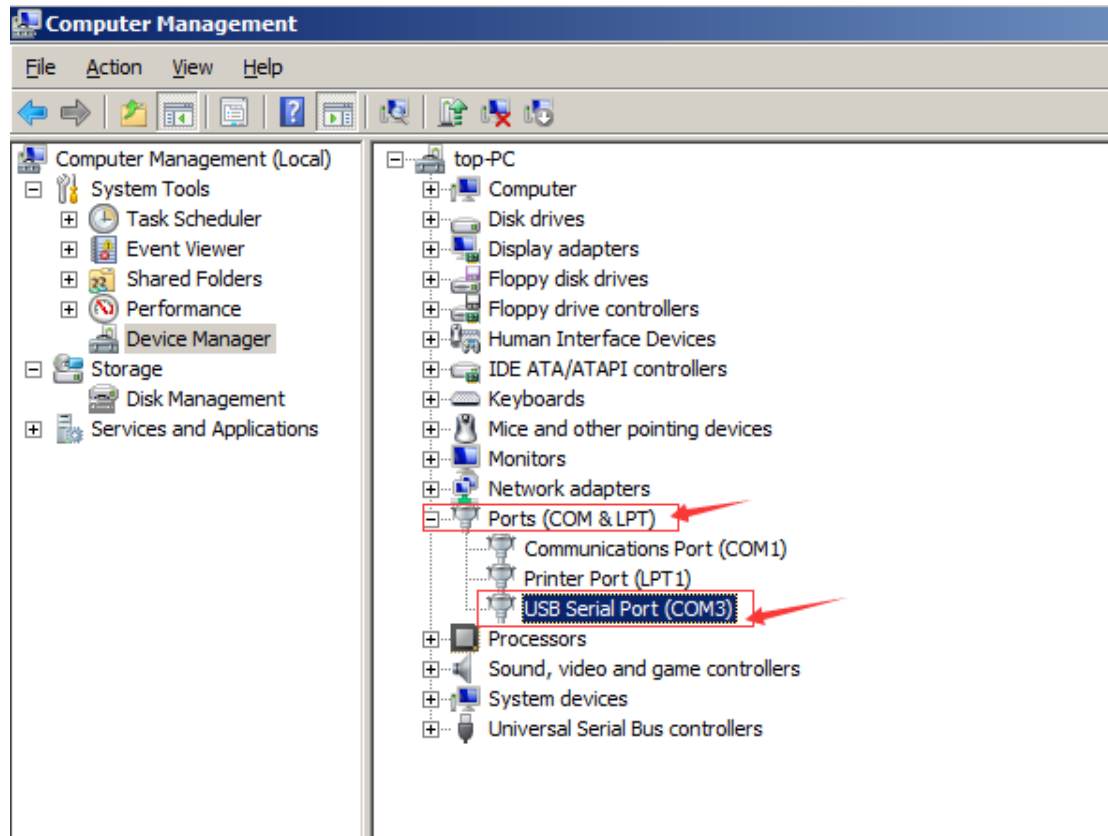

2. Change the COM port assigned by the computer

The USB Serial Port (COM3) under port (COM and LPT) directory displays the present allocated port number of the computer; port number changing steps are as follows.

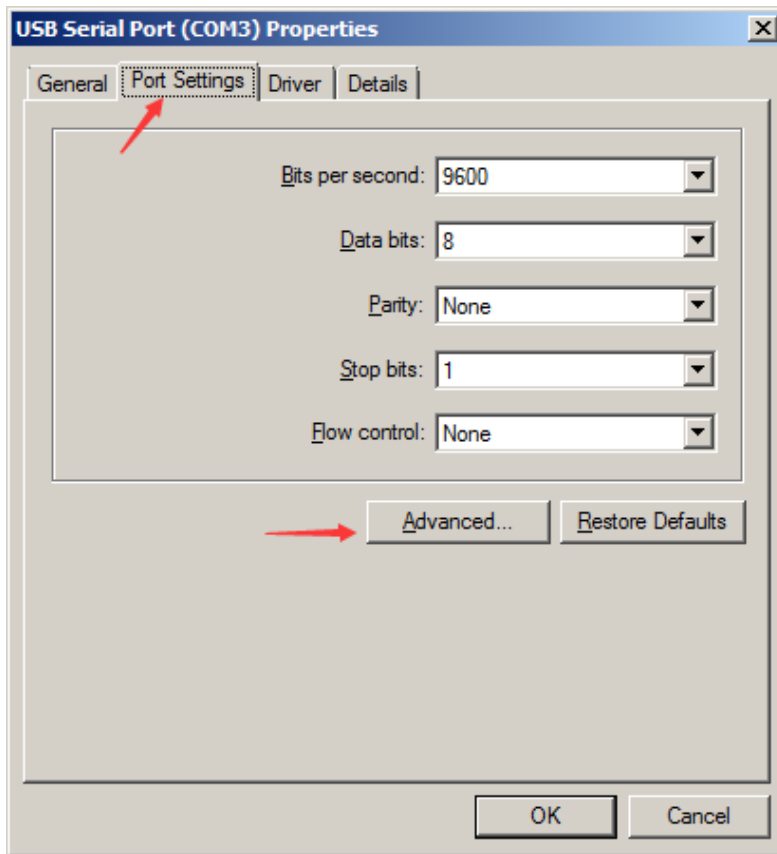

- 1) Double-click USB Serial Port (COM3), the USB Serial Port (COM3) properties dialog box would pop out, and then click "Port Settings"; Click "Advanced..." and "Advanced Settings for COM3" dialog box would appear.
- 2) Select the port number you want to set in COM3 port No. option box.

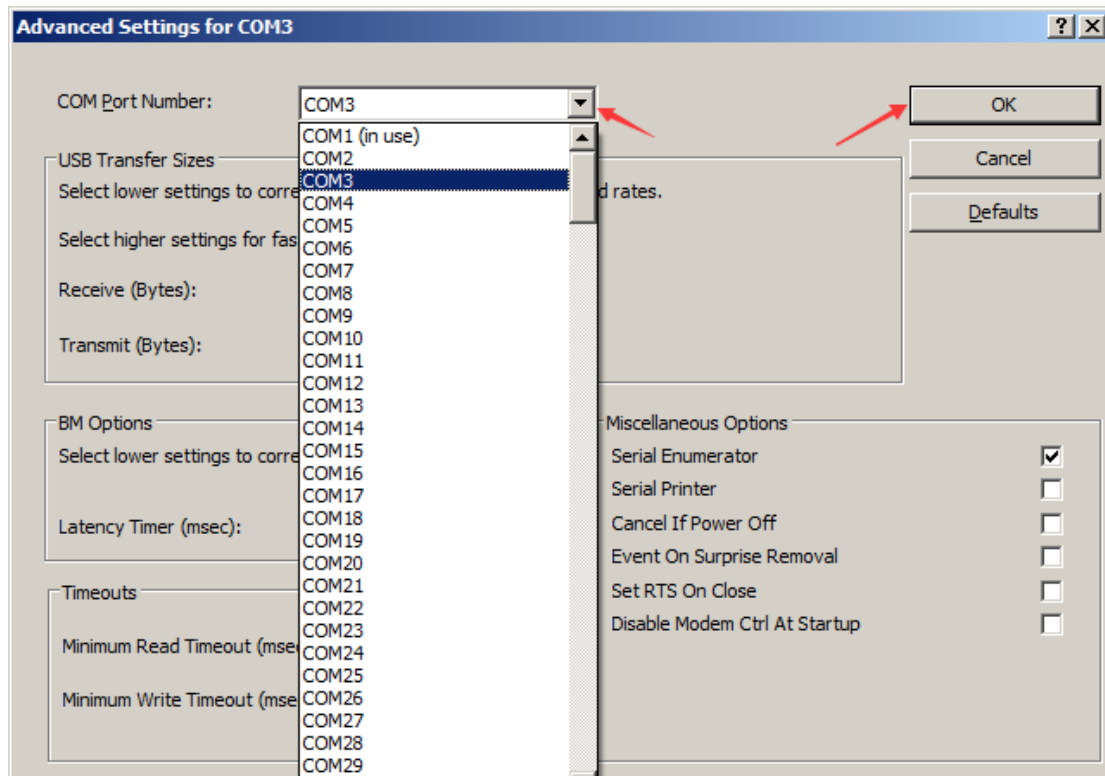

- 3) Click [OK] and the Communications Port Properties dialog box would pop out as shown in figure.

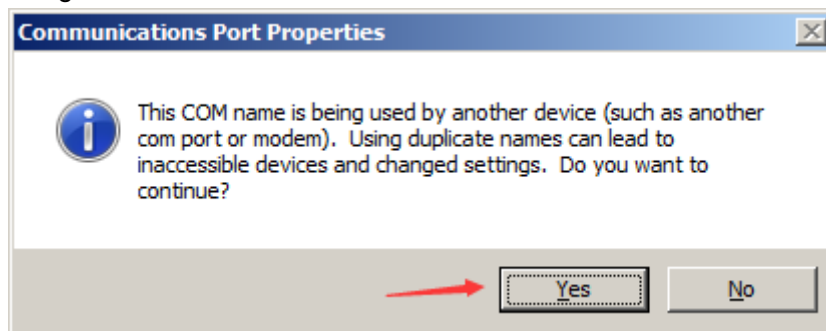

- 4) Click "Yes" and setting process is completed.
- 5) No display on the screen would indicate the machine is not connected to (Note: don't forget to install the USB driver and plug in the USB line).

1.4 Basic operation

1.4.1 Graphics array

1.4.1.1 Virtual array

The "Array" page on the right side of dialog box toolbar is shown as the fig. below. **If the Intelligence double laser heads machine is used, please select a virtual array to conduct type setting.**

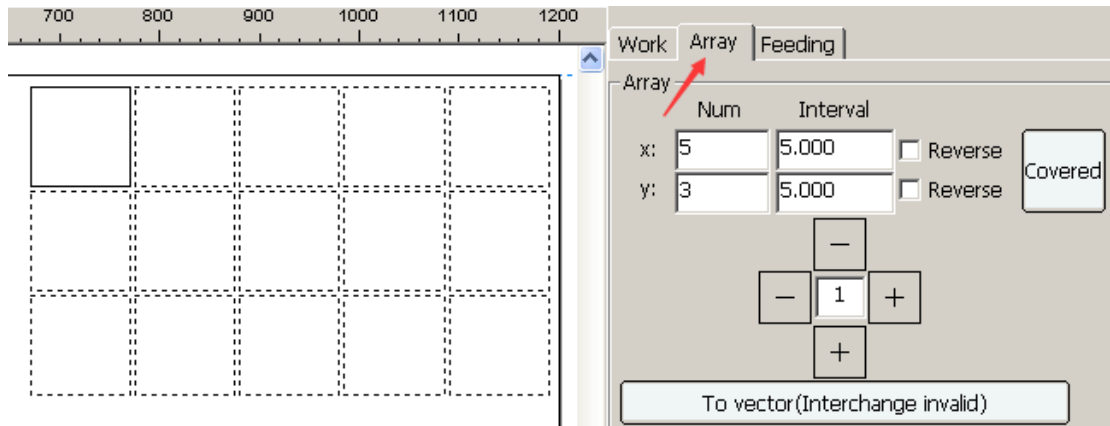

Press [Covered] button and automatic bestwren setting dialog box would pop up. Input array scope value(width and height), the software will calculate columns, rows and remaining size of a specified breadth side based on the width, height and the interval value input by the user. Calculated parameters would be refreshed on the "array" page, and generate a virtual graphic element.

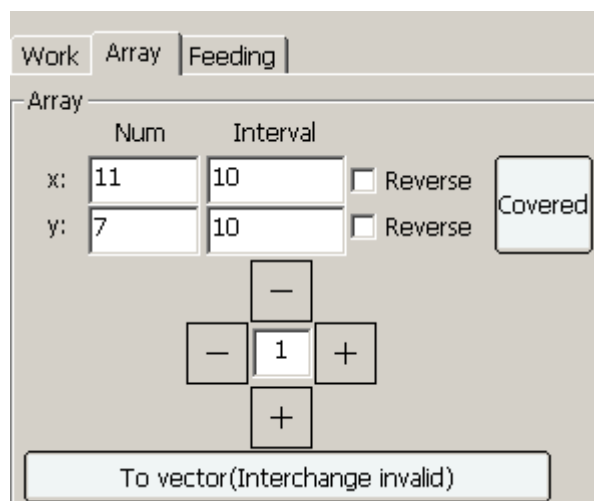
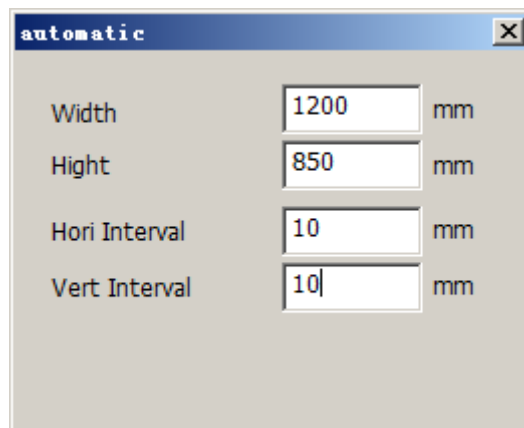

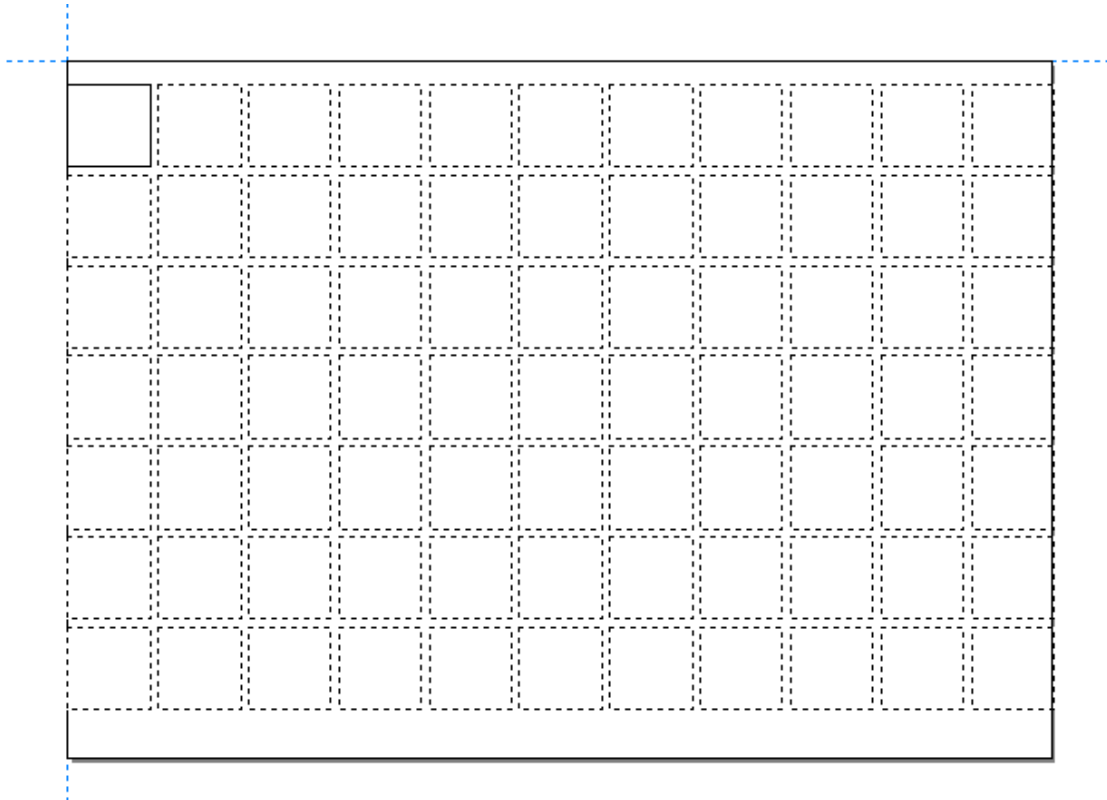

If bestrewn process isn't required of, input the number of columns x and its interval, and the number of rows y and its interval after selecting graphic element, then graphic array is generated.

1.4.1.2 Real array

Selected the graphic needs array.

1. Firstly, following the instruction of virtual array to generate the virtual array graphics.
2. Click the "To vector" button to convert the virtual array graphics to the real array graphics.

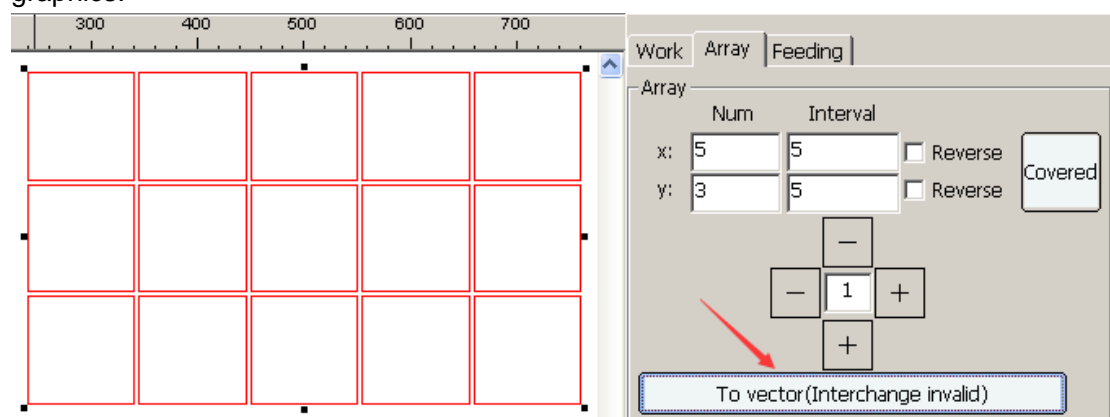

[Covered]: The utilization method of real array is the same as that of the virtual array. The difference between them is the final graphic element. Real array generates real graphic elements while virtual array generates virtue graphic elements.

NOTE: The virtual array can be converted to real array. But the real array is unable to convert to virtual array.

1.4.2 Nesting

Import the graphic into the laser software. Then select it and open the array page to find out the nesting function. Input the width, height, rotate angle, interval and mirror option parameters. Then click the “automatic” button to nest. It will generate the virtual array by default, it can be used by the intelligence double laser heads machine. Click the “Turn Solid Line” button to convert to the real array graphics. **When converting to real array, the graphics is only able to be processed by one laser head. So if it is an intelligence double laser heads machine, it is advised to use virtual array.**

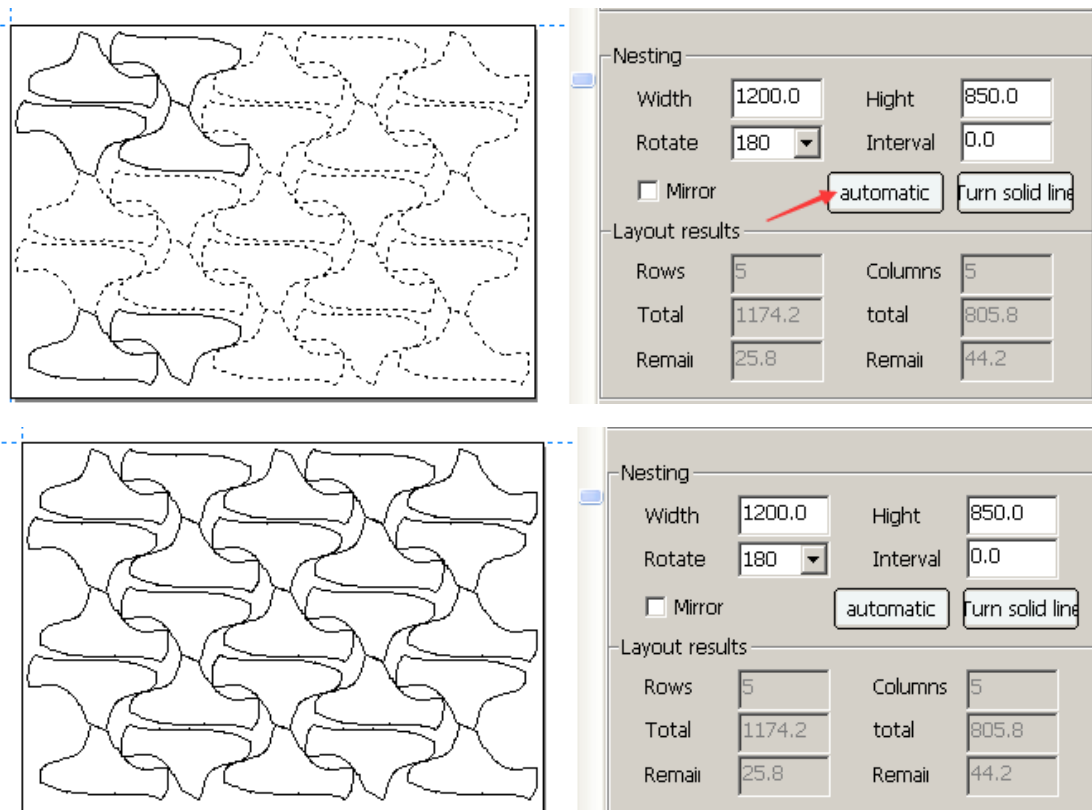

1.4.3 Data processing

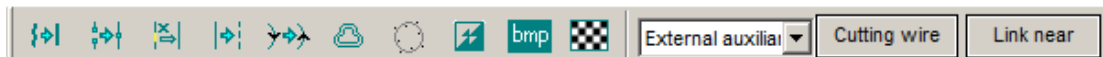

1.4.3.1 Lines merging

Lines merging function is a pre-treatment process to convert the curve of exceedingly high precision to that of more suitable size for the convenience of processing. Operation process is as follows:

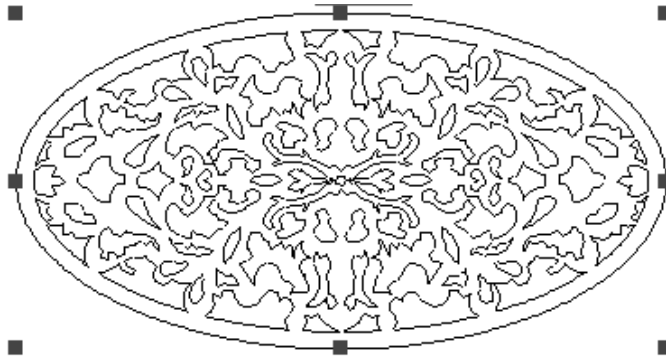

Select the graphics to be merged and click [Merge Line]



1.4.3.2 Adjacent merging

Adjacent merging function is the pre-treatment process for graphs failed to meet the standards. An entire graph but generated separately during drawing will make independent graphic element which should have one starting point and one final point separate into many independent segments. In such case, adjacent merging function could be used.

Click the  with the mouse and parameters settings are shown as below:

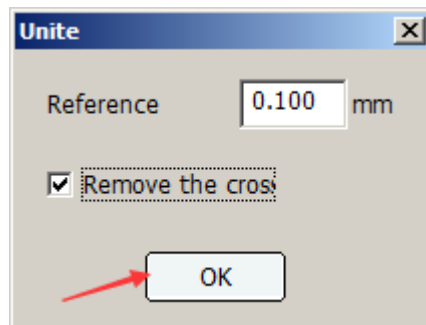

[Reference range]: Indicate the required maximum distance between the adjacent two lines of endpoints to be regarded as an entirety and to be merged.

[Remove the cross]: if endpoints of two lines meet demands of merger and there is intersection between the two lines, intersecting part should be removed. As shown in the figure:

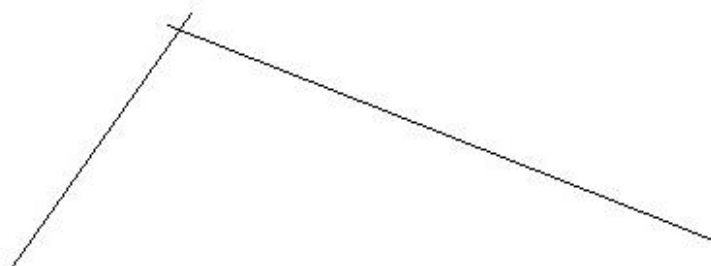

Changed to:

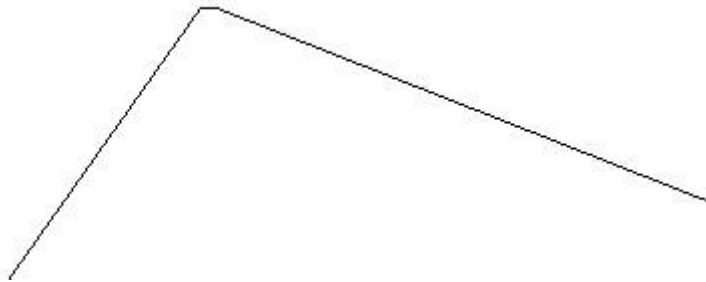

Two line segments are changed into a polygonal line.

1.4.3.3 Overlap delete



If three squares are connected and there is an overlapped boundary line in the middle of

each square, click "Delete coincident"  button as shown in the following fig.

A dialogue box would appear:

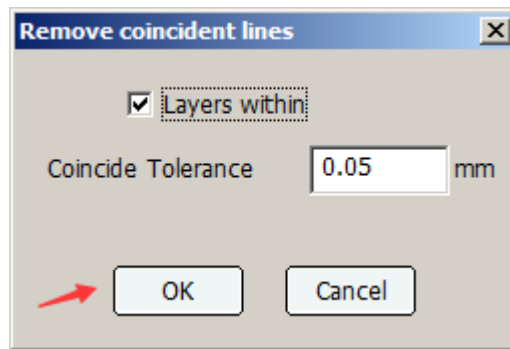

Select one rectangle and drag to move away and it can be seen after executing the above steps. For laser cutting, removal of redundant public side line can improve processing efficiency.

1.4.3.4 Processing lead line

Select the graphic element and click "Cutting wire" button; the following dialog box would appear. And there are two type of lead line [line] and [arc].

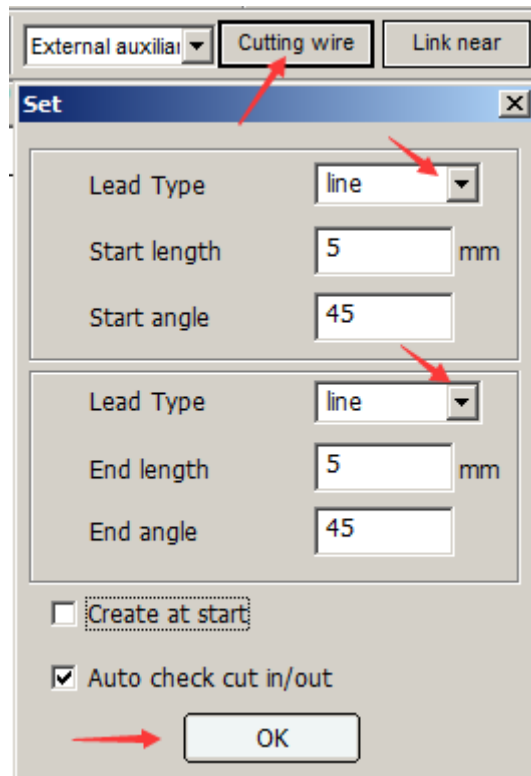

After click [OK], the interface turns to the following:

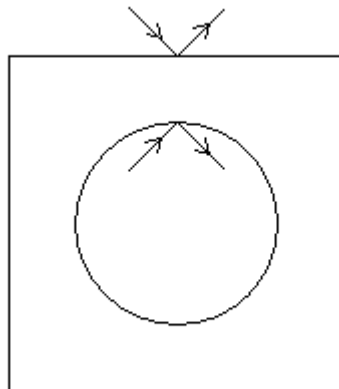

The direction angle and length of the lead line could be defined by the user.

1.4.3.5 Graphic element cutting direction

To edit the cutting direction of graphic, it has to click the  button to show the direction of the graphic.

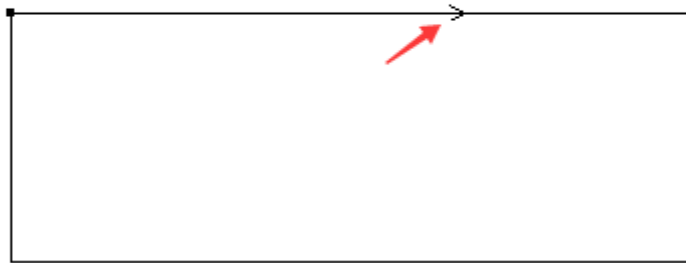
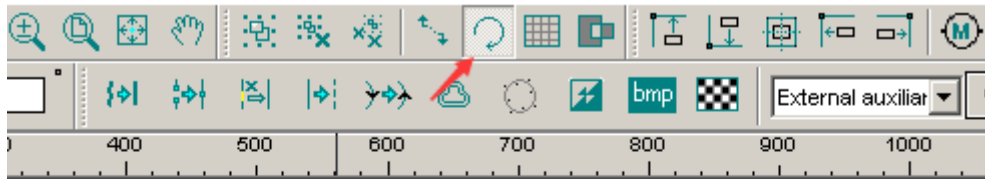

Click reverse direction  to change the direction.



1.4.3.6 Profile zooming

Make unified profile modifications for the original graphic to offset error generated from laser spot. Modification could be conducted through the upper toolbar button.



Select the graph, click  and the following picture would appear.

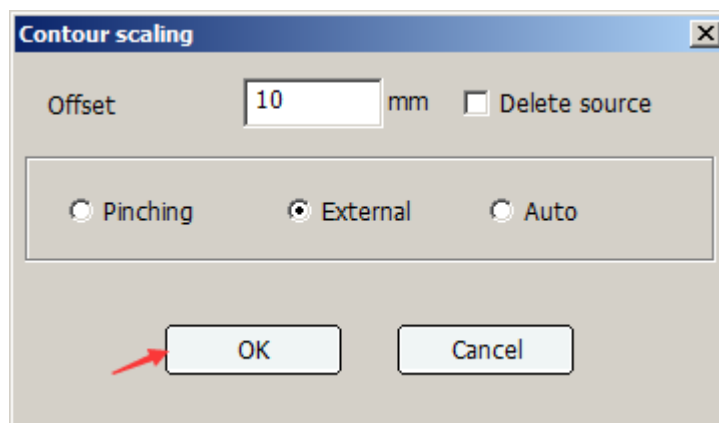

Set zoom model and parameters such as distance as required, and then click "OK" zoomed effects are shown as follows.

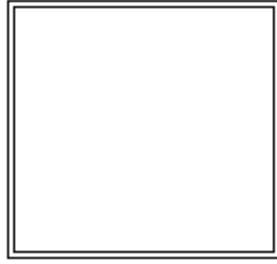

1.4.3.7 Smoothness



As for *.dst、*.dsb、*.plt type documents, if boundary lines are not smooth due to drawing, as shown in the fig. Below:

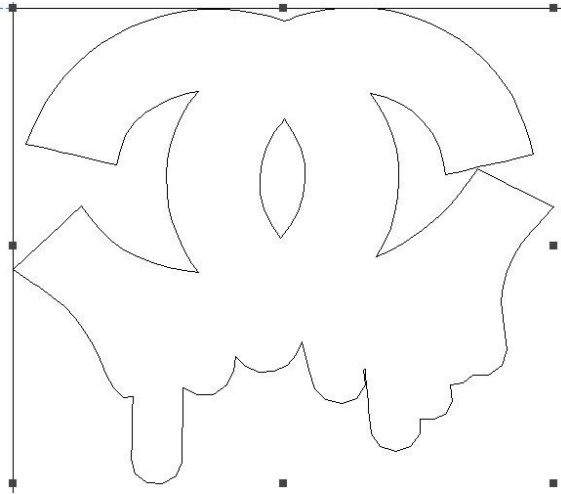

User can select the graphic and then click  tool to smooth the boundary line and thus processing effect turns more smooth.

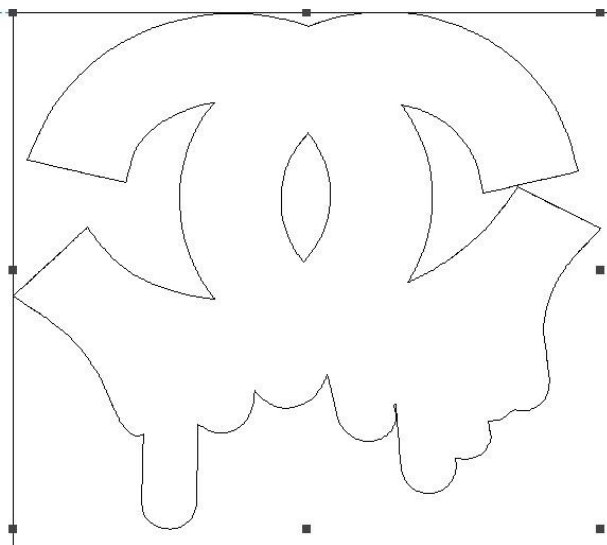

1.4.3.8 Bitmap color reverse



Select bitmap and click  to reverse the color.



Changed into:



Or



Changed into



1.4.3.9 Curve precision

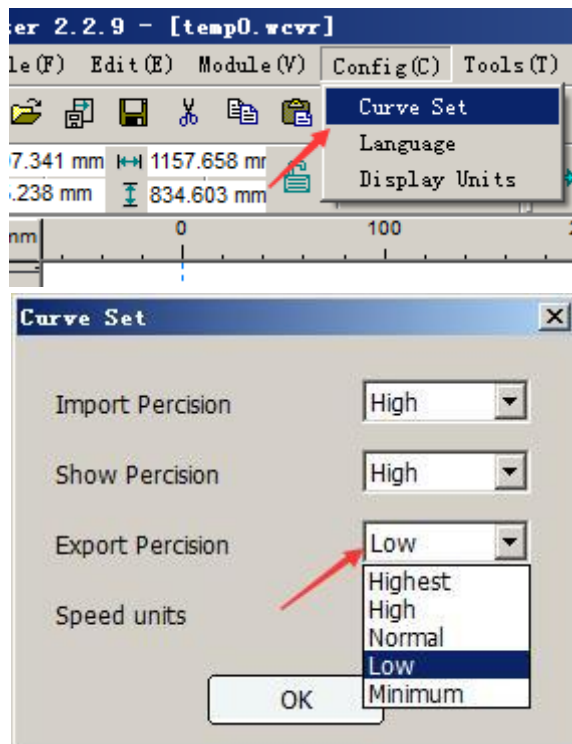

In order to make the user cut more flexible and at faster speed, curve precision can be set up to improve the flexibility and speed of the working-piece. The software offers options of Lowest, low, medium, high, highest for users.

1.4.4 Starting point setting

Starting point setting needs to be conducted on node edit mode, so users need to edit the node first.

Click the "Node"  button first. Then click element or press left key and hold to select part or all graphics element. Proper zoom in can enable the user to see the graphic element nodes more clearly.

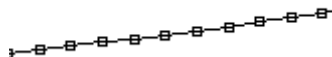

Move the mouse on a node, and left-click the selected node, then right-click to pop up the menu.

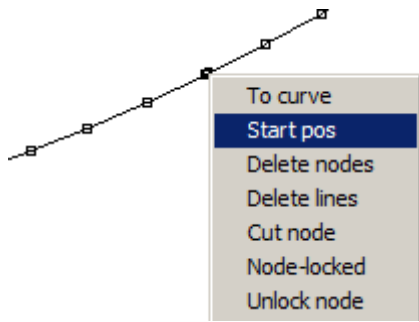

Click "Start pos" to set the start cutting point of this graphic.

1.4.5 Display

1.4.5.1 Processing order number display and manual sort

The processing order number display and manual sort tool is in the tool bar on the left side of the laser software.



Click **IVI** button to display graphic element processing order Number. And it goes into the manual sort stat. Click the graphic orderly and the processing order would change.

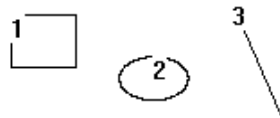

1.4.5.2 Jumper lines display

Graphics element display toolbar is at the upper part of the status bar, as shown in figure.



Click "Show jumper" button to display jumper lines between graphic elements.

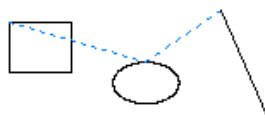

1.4.5.3 Processing direction and starting point display

Click "Show direction"  button to display cutting direction and the start point of graphic elements. Cutting direction and starting point is shown as below.

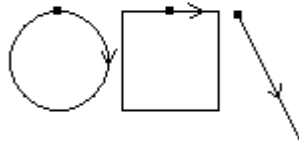

1.4.5.4 Carving effect display

Select the one graphic, and then click the  button to show the carving effect. Note the graphic in the layer is for carving.

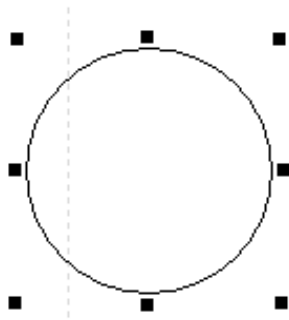

Before

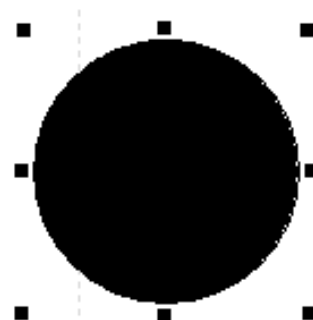

After

1.4.6 Bmp Processing

Select the one graphic, then click the  button to process the bmp graphic.

width	600	pixel
height	348	pixel
X Resolution	72	pixel / inc
Y Resolution	72	pixel / inc

<input type="checkbox"/> reverse	test
----------------------------------	------

brightness	0%	test
Contrast	0%	test

Resolution Modify		
pixel / inc	72	test

<input checked="" type="radio"/> Grayscale	test
<input type="radio"/> Binary image	

<input type="checkbox"/> Grid graph		
Dot size(mm)	0.2	test
<input type="checkbox"/> Diffusion ditherir		

OK

1.4.7 Group

It is able to group the graphics in the same layer or different layer. Select the graphics

need to group. Then Click “Group” button .

Before:

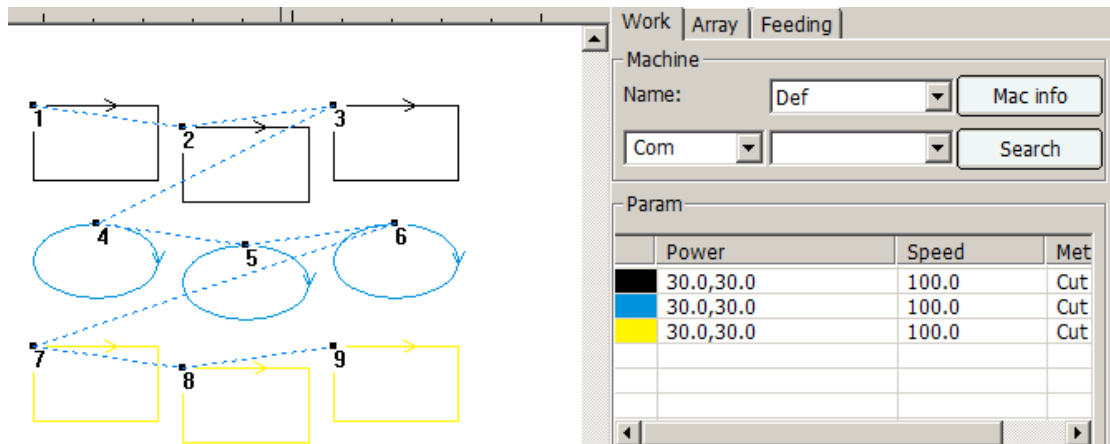

After:

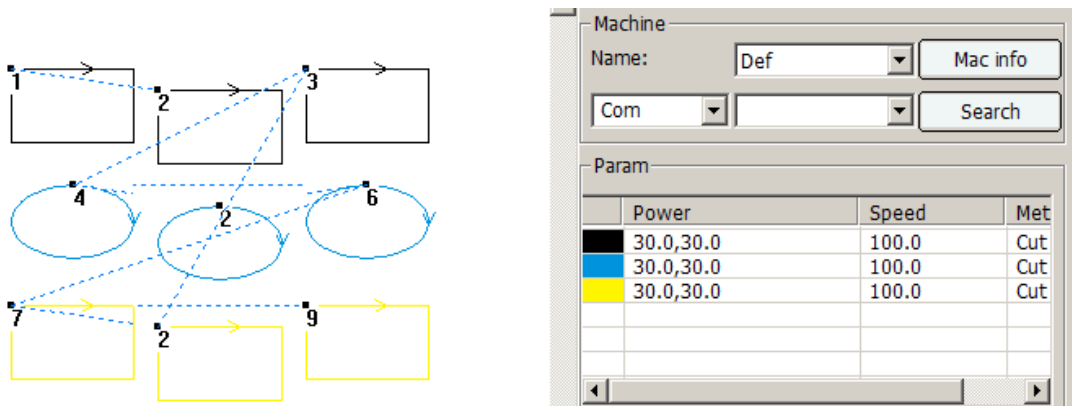

Note: The cutting path is changed when use the group function.

1.5 Output processing

1.5.1 Layer parameter

Layer parameters are set for colors. The graphics in the same color are used the same layer parameters. There is a layer parameter list under the "work" interface of the right side of the dialog box toolbar of the main interface.

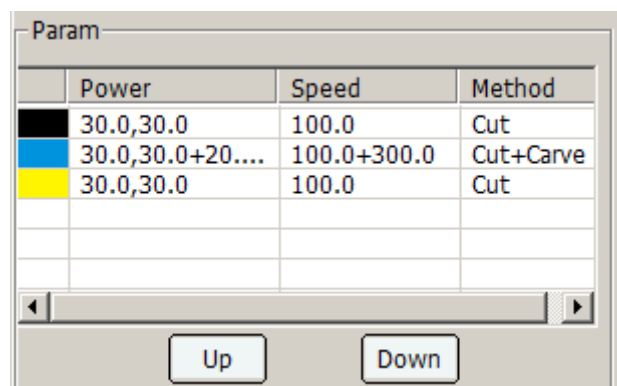

In the list, if the color order is top, then the graphic in this color will priority to be processed. After a layer is selected, click the [Up] or [Down] button to change the processing order.

Select a layer and double click the mouse to open parameter setting dialogue box as the figure shown below.

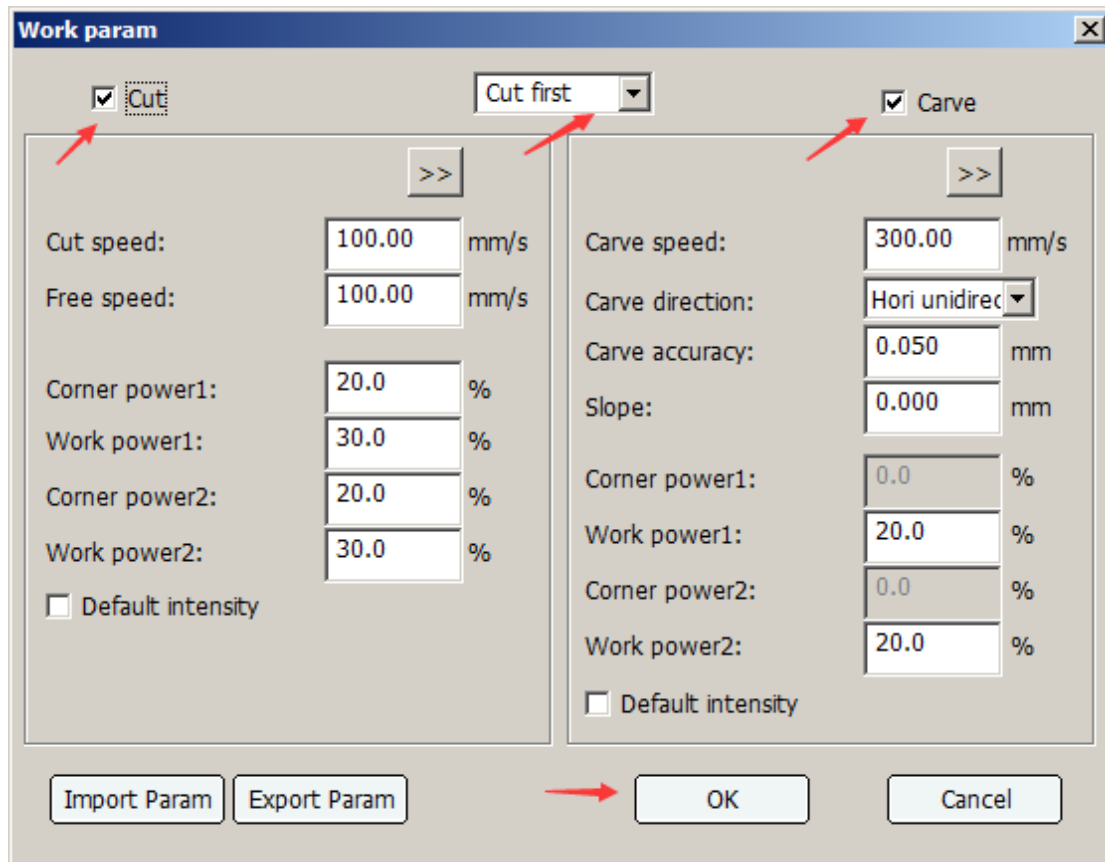

Set parameters for the present layer. It is able to import or export layer parameters use the “Import Param” and “Export Param” button.

1.5.1.1 Priority setting for cutting and carving

If a particular layer needs to be cut and carved, two kinds of processing order can be set by clicking list box.

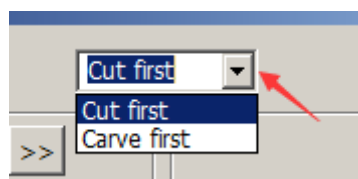

1.5.1.2 Cutting parameters

If cutting parameters needs to be set, select Cut option first.

Laser power1 parameter is targeted for the first laser, while laser power2 parameter is targeted for the second laser.

[Cut speed]: Refers to movement speed of laser head when cutting. When it is set to 0, the default processing speed of control card is adopted.

Cut Cut

Cut speed: mm/s
 Free speed: mm/s
 Corner power1: %
 Work power1: %
 Corner power2: %
 Work power2: %
 Default intensity

[Free speed]: Refers to movement speed of laser head with laser off or non-processing status. When it is set to 0, the default processing speed of control card is adopted.

[Corner power]: Refers to the laser power of the laser at the turning corner.

[Working power]: Refers to the laser power of the while it arriving at the cutting speed.

[Default intensity]: When the default intensity is selected, default intensity parameter in the control card would be adopted.

[> >]: Click the extension button, and cutting extension settings dialog box would pop up.

[Blowing]: Defines whether fan is started in the machine working process; if [Blowing] is clicked, and [Auto Ctrl] is clicked, the machine will only “blowing” when laser on; if [Blowing] is clicked, while [Auto Ctrl] is not clicked, the machine will “blow” through the whole process.

[Punch time]: Defines the specified waiting time of the laser on during drilling.

[Punch delay]: Defines the specified waiting time of the laser off during drilling.

[Power]: Refers to light power intensity during drilling.

[Pulse drilling]: Refers to continuous and repeated perforation in one place.

[Start punch times]: Refers to the times for machines to conduct pulse drilling at the starting point.

[End punch times]: Refers to the times for machines to conduct pulse drilling at the end point.

[Point mode]: Refers to the working mode in which the user is allowed to make continuous line graphics in discontinuous dots pattern.

[Interval]: The distance between dots.

[Delay]: Refers to the delay times of processing dot.

[Delay after layer processing]: Refers to the residence time in the same place after layer processing is completed.

[Pause after layer processing]: Refers to work pause after layer processing is completed.

[Pen mode]: When pen model is started, set its offset between the pen and the laser

head, and set the delay for pen rising / falling.

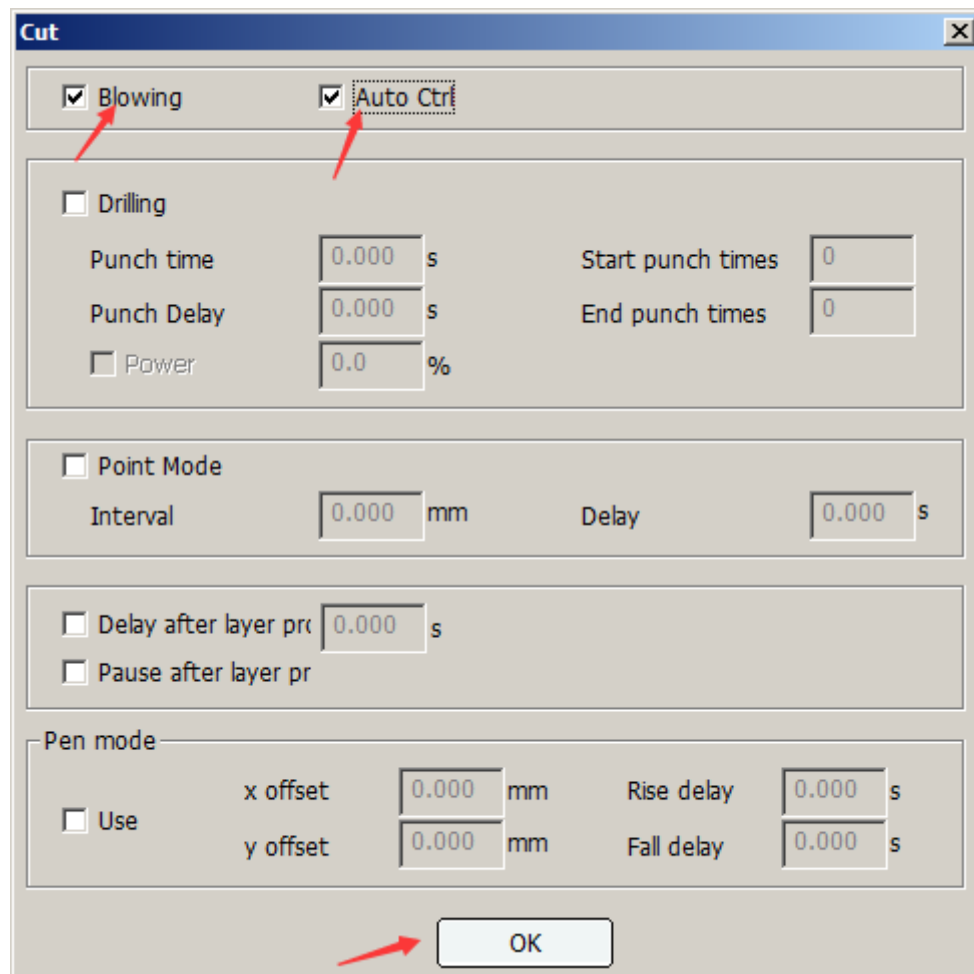

1.5.1.3 Carving parameter

Select "Carve" option before setting carving parameters.

[Carve speed]: Refers to the working speed.

[Carve direction]: Refers to working method during engraving process, including "Horizontal unidirectional", "Horizontal two-way horizontal" and "Vertical unidirectional" and "Vertical two-way" modes.

[Carving accuracy]: Refers to the interval distance between the adjacent two carving lines.

[Gradient]: Refers to the gradient length set for slope carving. Corner power determines the top depth. The deeper the corner power, the greater the top depth. Work power decides the depth of the graphics. The greater the power value, the deeper the depth. Slope distance determines the distance from the top to the bottom, the longer the distance, the flatter the slope.

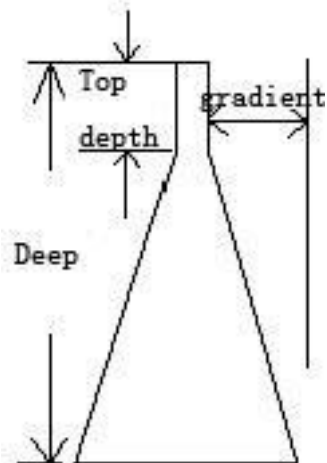

[Corner power]: Refers to the light intensity of slope carving depth in processing.

[Work power]: Refers to the light intensity of carving process or the light intensity at the deepest location of the processing graphic when slopes are carved.

<input checked="" type="checkbox"/> Carve	
>>	
Carve speed:	300.00 mm/s
Carve direction:	Hori unidirec
Carve accuracy:	0.050 mm
Slope:	0.000 mm
Corner power1:	0.0 %
Work power1:	20.0 %
Corner power2:	0.0 %
Work power2:	20.0 %
<input type="checkbox"/> Default intensity	

[> >]: Click the extend button, carving extension setting dialog box would pop up, then click open:

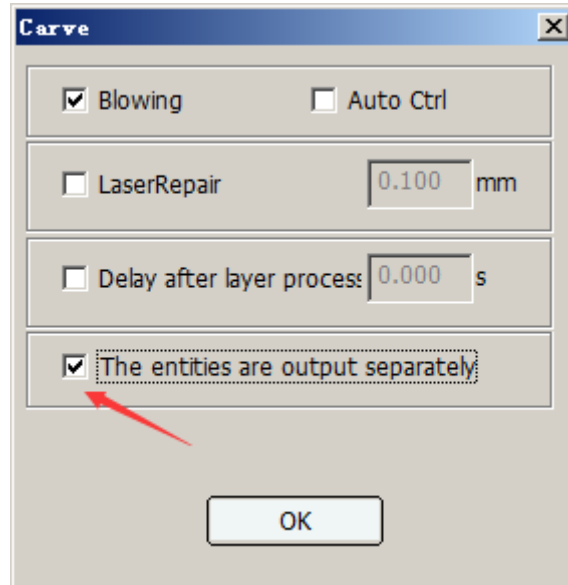

[Blowing]: Defines whether the fan is started in the machine working process; if [Blowing] and [Auto Ctrl] is clicked, the machine will “blow” when it is engraving; if [Blowing] is Clicked, but [Auto Ctrl] is not clicked, the machine will “blowing” through the whole process.

[LaserRepair]: Refers to compensation for problems such as small size or fuzziness of processing graphics. After setting the spot diameter (mm), click the check box button aside to enable this compensation function

[Delay after layer processing]: Refers to the delay and pause time after layer processing is completed. Set the delay time (in seconds), click the check box button aside to enable the function.

[Graphics output respectively]: Refers to the vector graphics that is carved one after another. The result is shown as below.

Before:

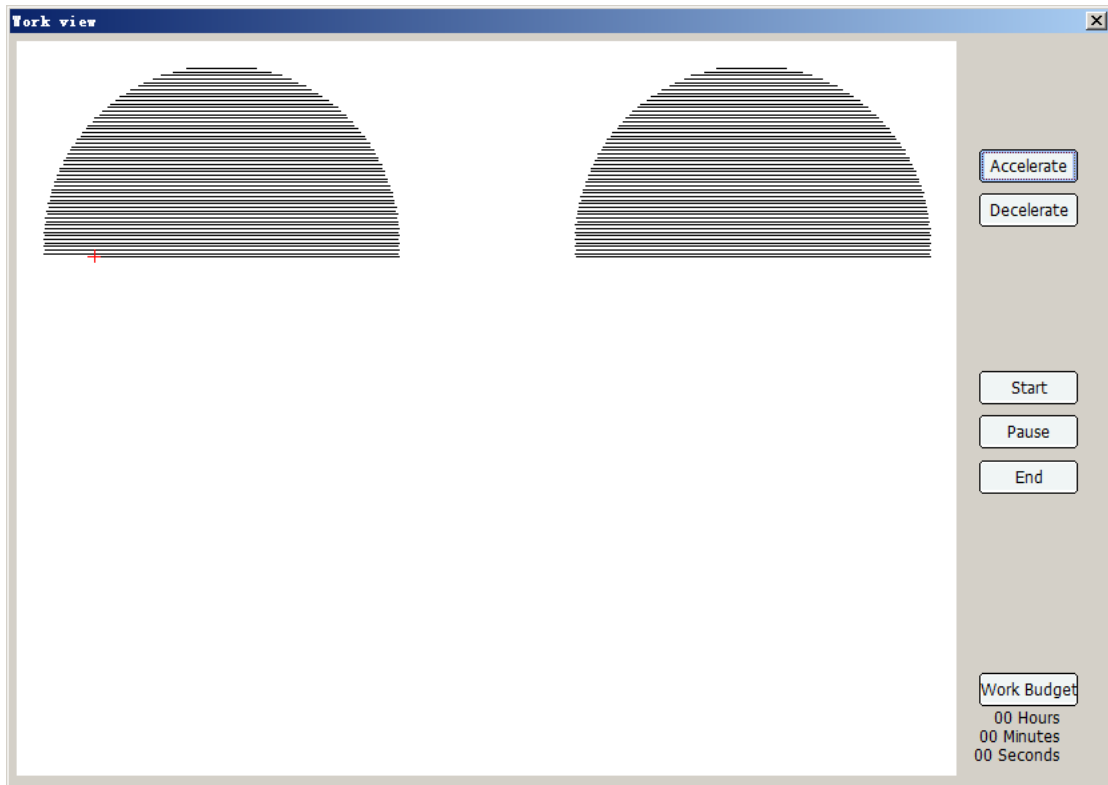

After:

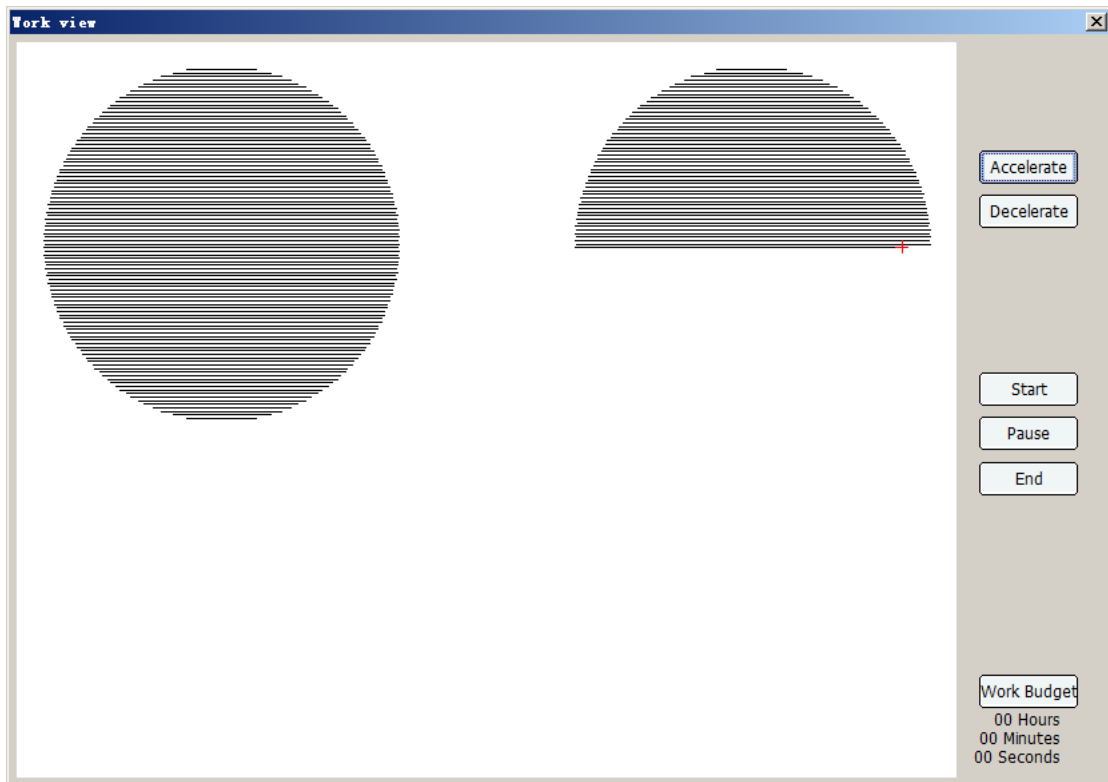

1.5.2 Route optimization

Before downloading graphics, in order to make it to process in specific route , and to improve the processing speed while optimizing its route, select [Download], at the bottom right part of the Download interface, and then click [Path optimization], click [<<] button

and access into route setup dialog box.

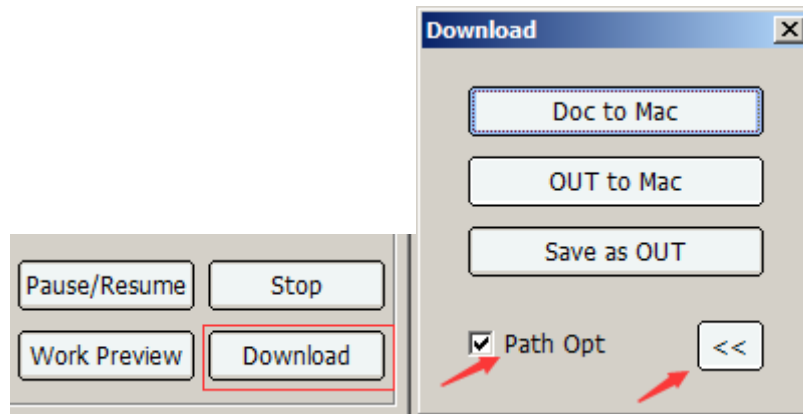

The following interface would pop up after clicking << button.

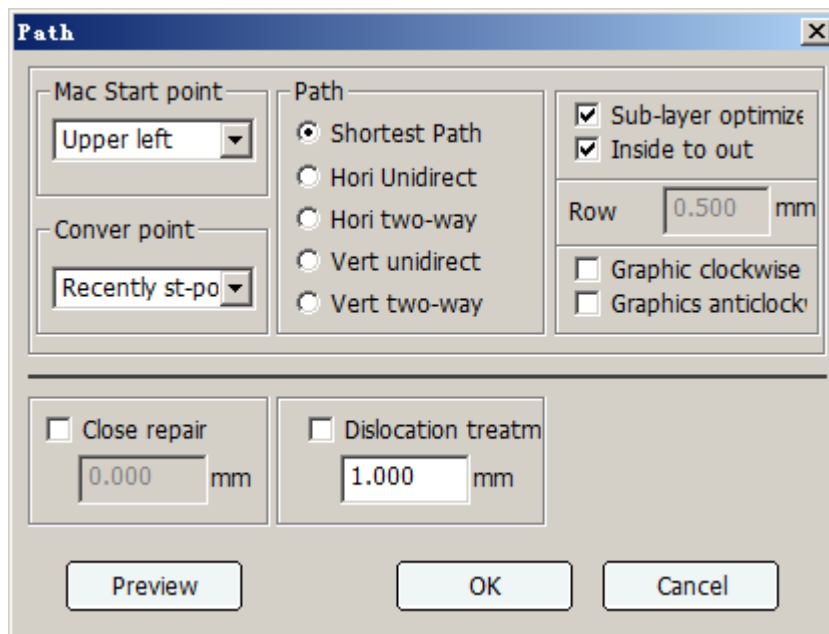

1.5.2.1 Route optimization type

Route optimization includes: shortest route, horizontal unidirectional route, horizontal two-way route, vertical unidirectional route, vertical two-way route and original route.

[Shortest Path]: For non-arrayed graphics, take the shortest moving distance route of laser head as the processing route.

[Horizontal unidirectional route]: For arrayed graphics or graphics of regular arrangement, process from left to right by lines. The processing direction of closed curve in the same line should be the same, either anticlockwise or clockwise

[Horizontal two-way route]: For arrayed graphics or graphics of regular arrangement, process from left to right in S shapes, either anticlockwise or clockwise.(e.g., some line is processed from left to right, and the following line will be processed from right to left.)

[Vertical unidirectional route]: For arrayed graphics or graphics of regular arrangement, process from top to bottom, closed curve of the same column should be processed at the same direction, either anticlockwise or clockwise.

[Vertical two-way route]: For arrayed graphics or graphics of regular arrangement,

process in S shape in rows, either anticlockwise or clockwise.(e.g., a column would be processed from top to bottom, followed by a row processed from the bottom to up.)

[Original path]: No optimization for any route. Without clicking the “Path Opt” check box to choose the original path.

1.5.2.2 Additional parameters

[Starting point]: Indicate the graph starting point from which work starts (upper left, upper right, lower left and lower right, etc.).

[Optimization in layers]: Whether optimization can be conducted in the inside layer or is allowed to be optimized across layers.

[From inside out]: First process small graphs inside and then process outer bigger graphics.

[The closest starting point]: Modify the original graph starting point to make traveling shifts distance became the shortest.

[Smooth starting point]: Modify the original starting point and to make the speed change become most gentle.

[Original starting point]: The starting point whose original graph is not modified (applicable to manually specified starting point or graphs added with lead).

1.5.2.3 Dislocation treatment

When processing parts size is inconsistent or sealing dislocation occurs and thus causing working piece failed to be cut, click the option and the problem is solved. Click check box

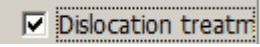
of dislocation treatment  , no matter whether the route is optimized or not, dislocation treatment is conducted.

1.5.2.4 Close compensation

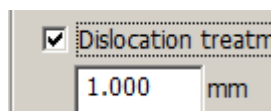

When materials are cut, as the minimum light intensity of the laser tube may not agree with photo sensitivity of the material and processing speed, the sealed part of closed graph may not be cut or carved. The software has a function of "close compensation" to over cut a certain distance at the sealed openings to solve the problem. Set the distance value according to the actual need. Click the closed compensation check box

 , execute closed compensation no matter route is optimized or not.

1.5.3 Work pre-treatment

1.5.3.1 Frame preview

Before processing, border view can be selected to check the dimension side of the processing graphic. Software main interface on the right side of the dialog box toolbar "work" page is as shown in the figure below

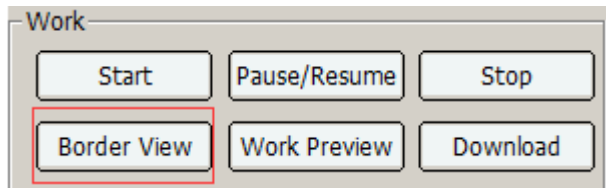

[Border View]: Click [Border View] button and the following interface is shown.

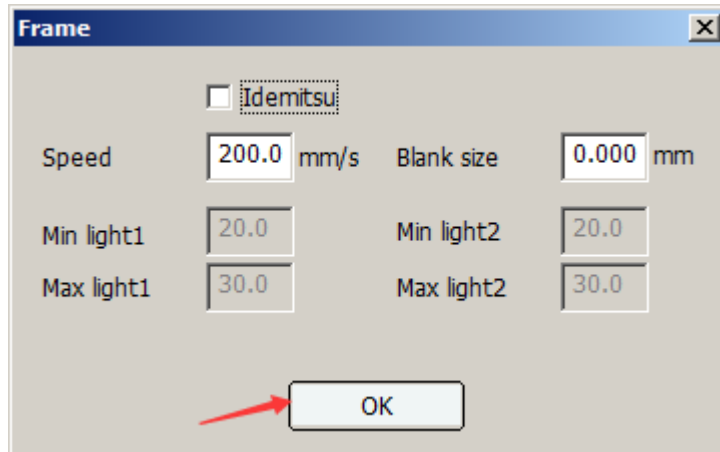

If there is a ready graphics file, it will walk along enclosing rectangles of present files starting from the anchor point. Set the movement speed and the blank size. If cutting border is required, set the min/max light power and click the “Idemitsu” check button.

1.5.3.2 Work preview

The right side of the dialog box toolbar "work" page is shown in the figure as below:

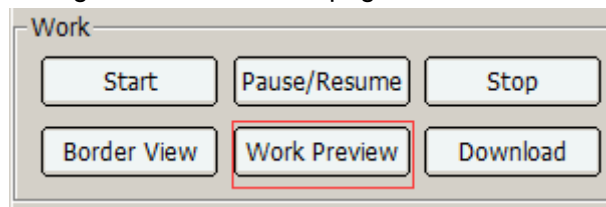

[Work preview]: The working file to be downloaded to the machine can be processed in simulation to check the processing route, etc.

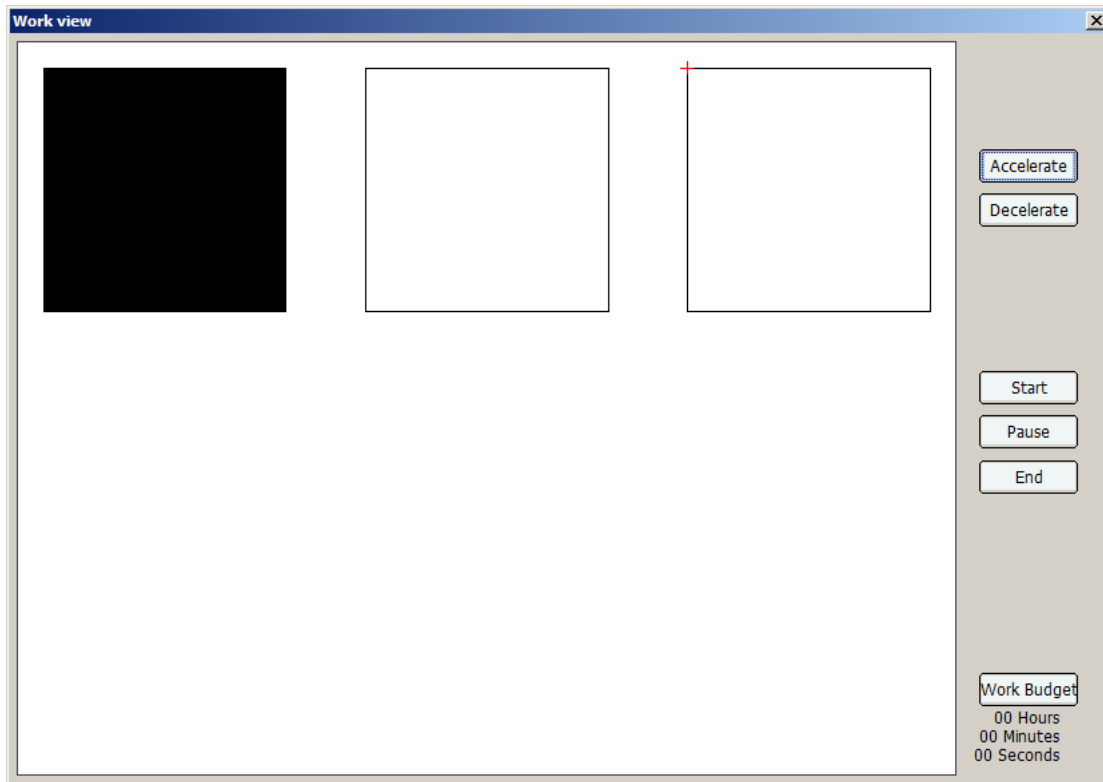

[Start]: To start the processing of simulation.

[Pause]: Pause the simulation process.

[End]: Stop simulation processing.

[Accelerate]: To speed up the simulation process.

[Decelerate]: To reduce the simulation processing speed.

[Working Estimate]: To estimate the processing time of the file (need to read the parameters of the control card).

1.5.4 Output processing

After the processing parameters is set, output processing can be conducted, as shown in the fig. below

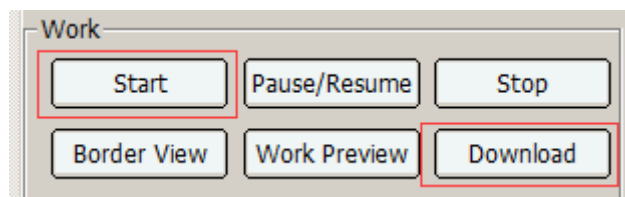

[Start]: Download the current file to controller and take the files as processing files to start work directly.

[Pause/continue]: To continue or suspend processing

[Stop]: Stop processing

[Download]: Click "Download" button and the following dialogue box would pop up.

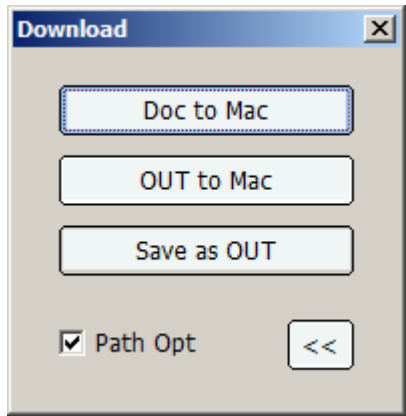

[Doc to Mac]: Download the current file to controller (will not directly work).

[OUT to Mac]: Download the out file saved before to controller (will not directly work).

[Save as OUT]: Save current file in processing format (*.out file type) to designate path of the computer.

1.5.5 Manual control

It is able to control the machine to move, laser fire, origin, pulse. If "Precise" is clicked, set the distance to move, 100mm etc. then click the direction button or Z/U/V+/- button move axis. If laser is need to fire on when moving axis, click the "Laser" check box.

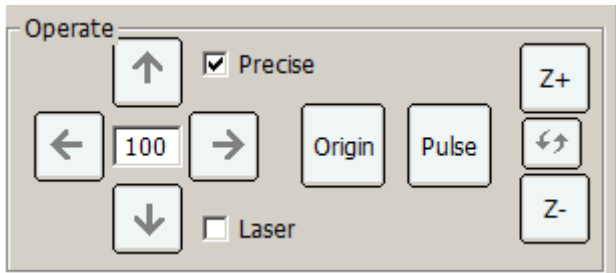

Select "Change" button to select Axis Z, U or V.

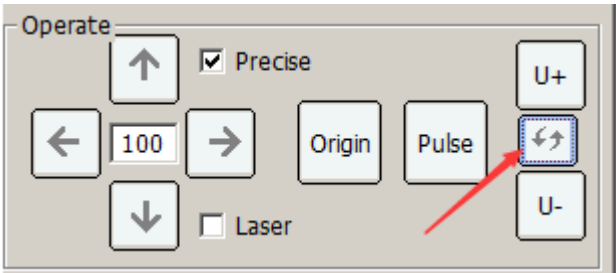

1.6 Case application

1.6.1 General output processing

This section offers an application example. To open a ready graphics for editing and fill layer parameters and then download to the processing program.

- 1) Open file

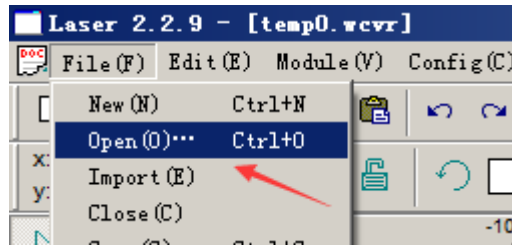

As shown in figure, click [File] → [Open] in the main menu and open dialog box would pop up. Find the saving route for “001.dsb” and then Click [Preview] and the file preview could be seen , then click open to open the file.

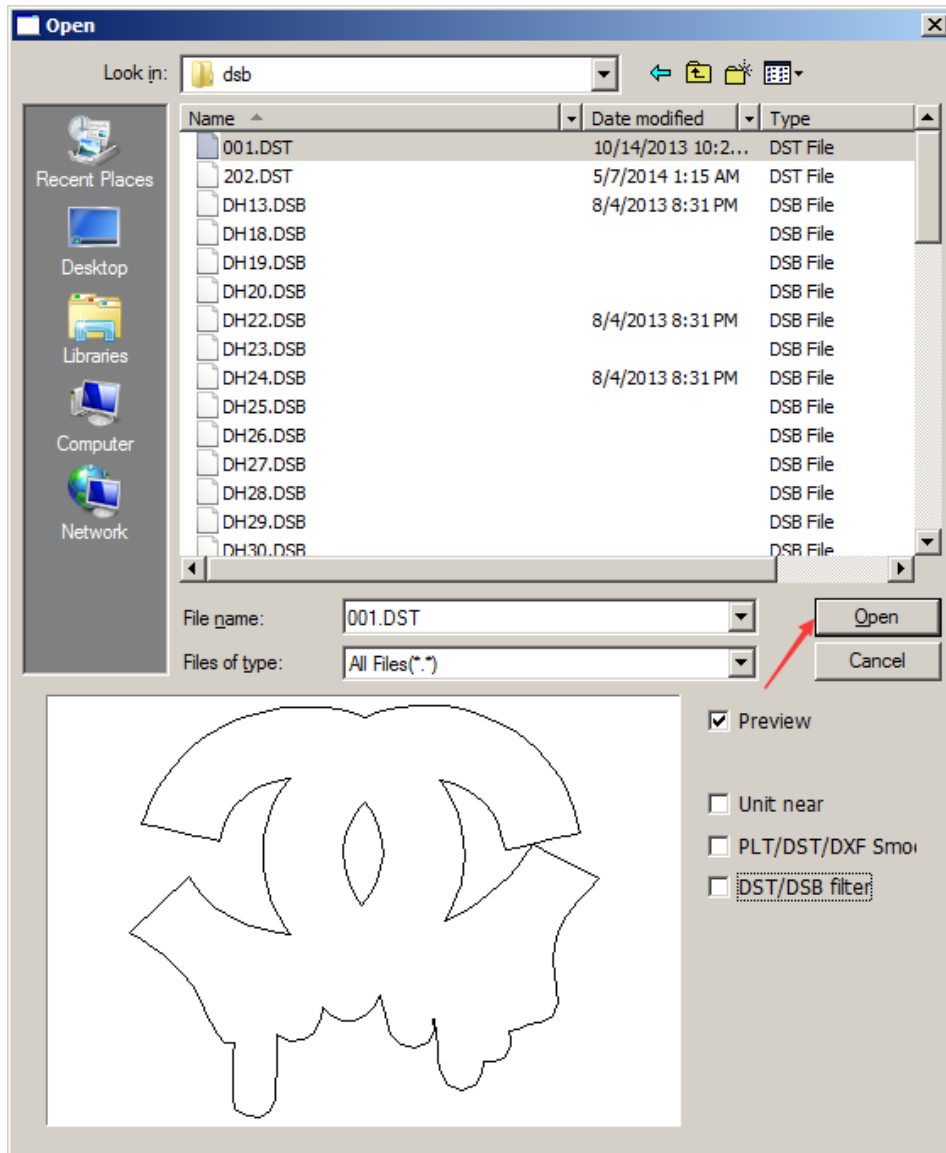

2) Edit

After the file is opened, the curve part of bottom is shown in line segments where turning corner could be clearly seen. The segments are not ideal smooth curves and need to be edited. Select the graphics and click the  tool on the toolbar for editing, and the curve became smooth. Then the next step of editing layer parameters could be conducted.

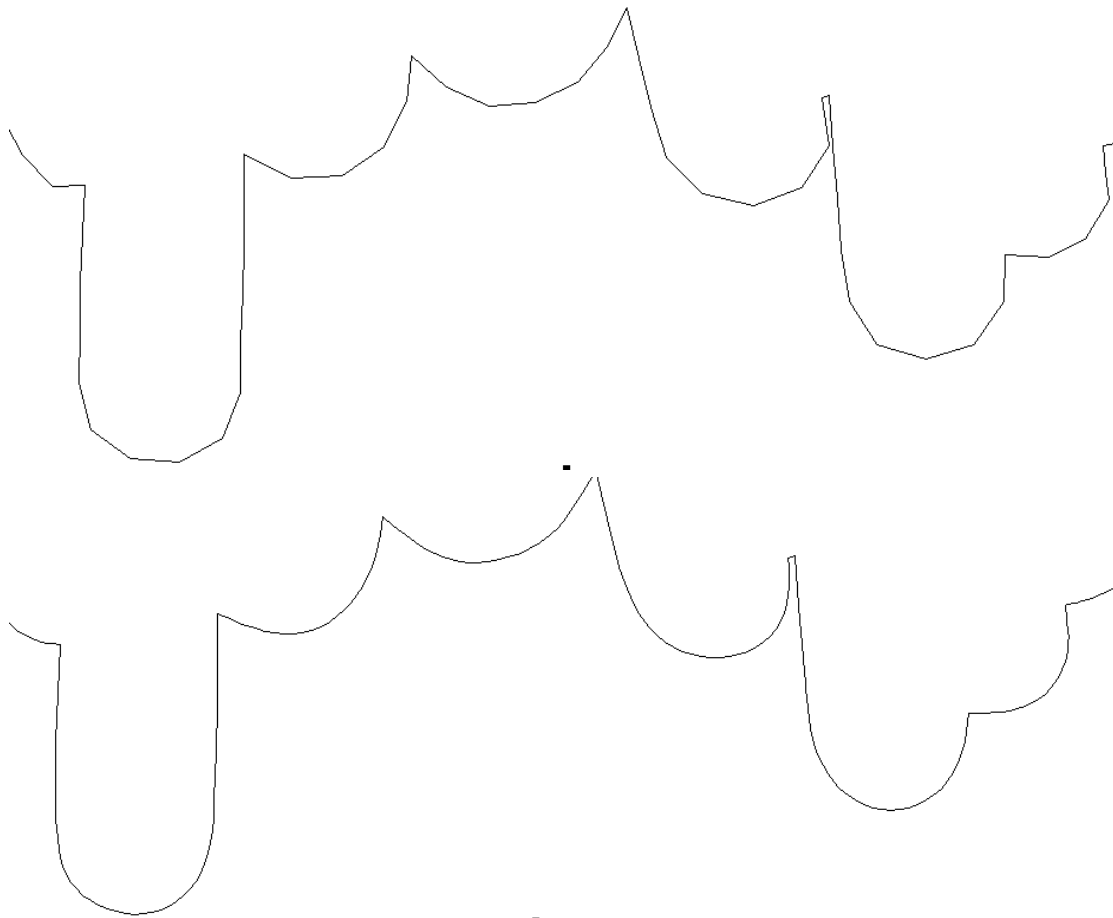

3) Parameter filling

There is only one color for the whole graphic, that is, there is only one layer. Therefore only one layer could be seen in the layer table. Double click item list one, and open parameters editing dialog box of such layer, Click [Cut] and remove the Click of [Carve]. Click [OK] after filling in parameters of power and speed, processing parameter editing is accomplished.

Param			
	Power	Speed	Met
■	30.0,30.0	100.0	Cut

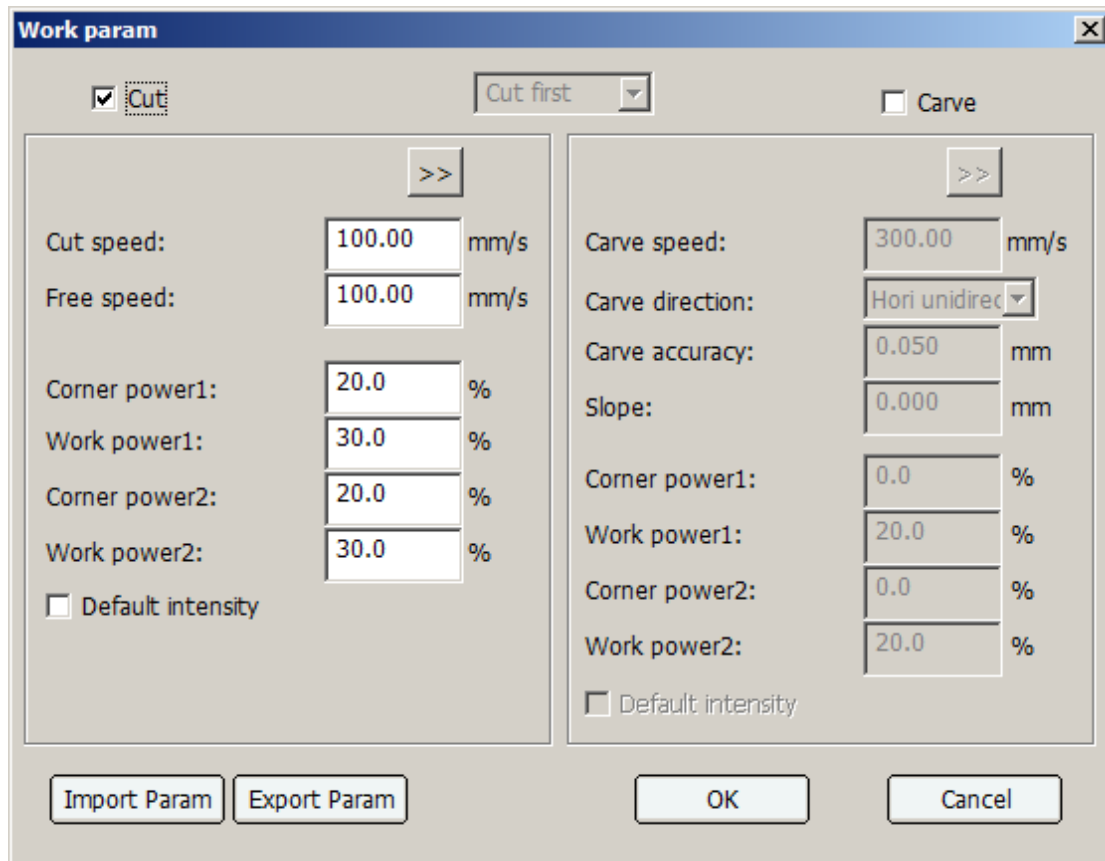

4) Download

After editing the graphics and filling the processing parameters, downloading can be conducted. Select communication mode before downloading (Details could be referred to communication specification) and plug in corresponding communication cables.

Click [Download] button and dialog box would pop up.

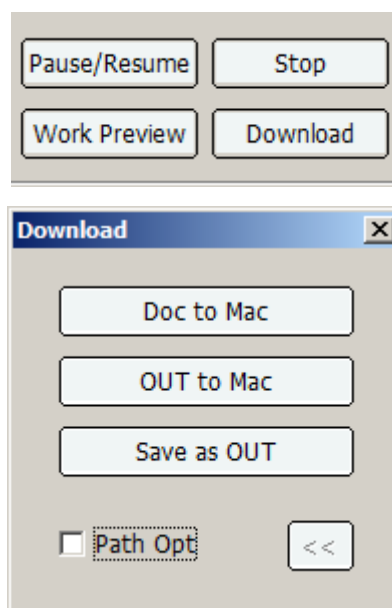

If route optimization is required, please click the [Path optimization], otherwise original route would be adopted. In this case, route optimization is not clicked. Then press [Doc to Mac] button, file name would pop up and input it into the dialogue box.

File name can be generated by default or manually input, the length of the file name should be no more than eight characters, any character beyond will be discarded. Click **[OK]**: Press OK to download. After download bar finished progressing, control card would make a "Di" sound. If a graphic could be seen on the control panel, download is completed successfully, otherwise, it is failed. Checking of communication cable connection is needed and this whole process should be repeated.

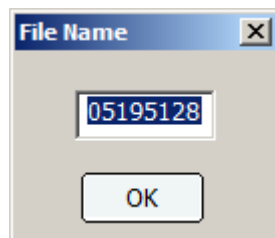

1.6.2 Curve smoothing

- 1) Click the [Module] / [Curve smoothing].

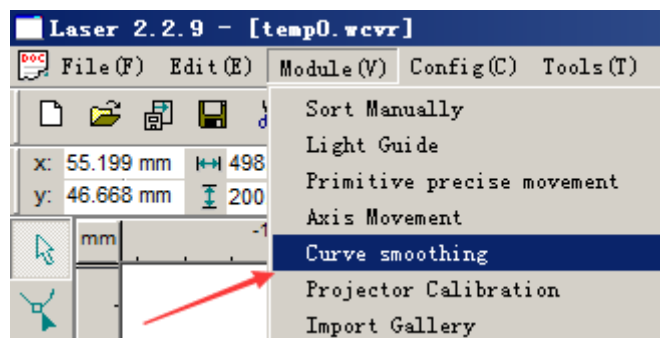

- 2) The Curve smoothing page will display.

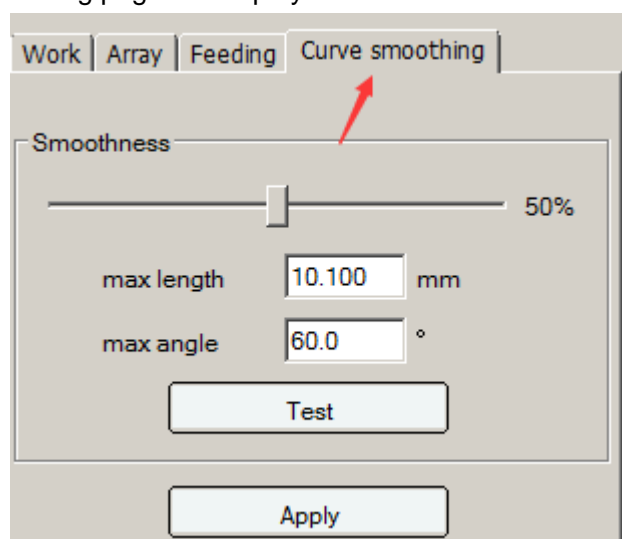

- 3) Drag the smoothness button to set the percentage. Click "Test" to view the smooth effect, click "Apply" to change.

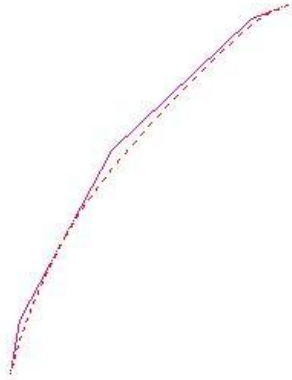

Before



After

1.6.3 Intelligent double shift processing

Using virtual array functions with added extra leftover material graphics can realize the leftover material function. As shown in the fig. below.

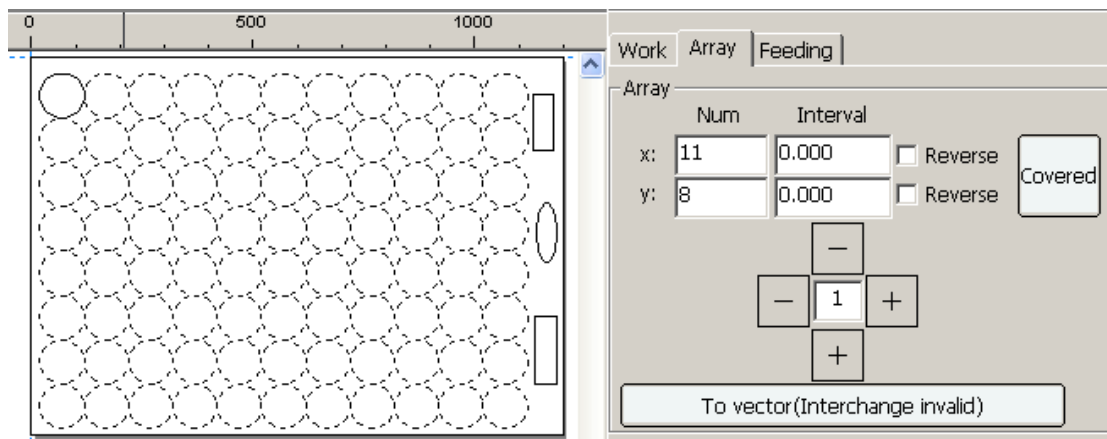

If the machine is an intelligent double head model, it will automatically work in separate mode when virtual array is being cut. When the end of the leftover material is cut, closest laser head will be selected automatically to work.

If dislocated material layout is required, two or more graphics could be arranged manually first, and then conduct grouping. After grouping, virtual array would be conducted.

Virtual array direction is controlled by machine coordinate system and the anchor point position. Choose "reverse" to modify the corresponding direction of the array.

1.6.4 Feed processing

For machines with installation of the feeding device, working-feeding - working cycling mode can be realized.

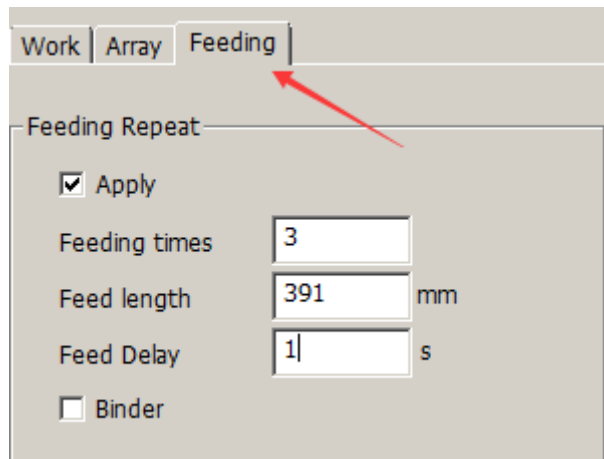

[Feeding times]: Refer to the times for working and feeding. If working process is conducted once, feeding is conducted once. And this working cycle would be continued as such.

[Feed length]: Refer to the length of feeding.

[Feed Delay]: Refer to the delay operation after feeding.

After the parameters is set, the "Apply" button need to be clicked. If feeding isn't needed, do not click the "Apply" button.

1.6.5 Large file segmentation processing

If the processing file length is too long and exceeds the vertical dimension of machine, and if the machine has the feeding function, large file segmentation processing function could be started.

Parameter settings for large file segmentation

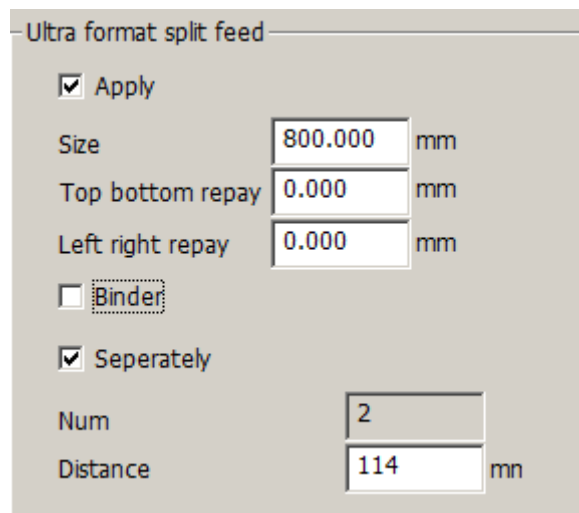

[Size]: The parameter should be no greater than the vertical dimension of the machine.

[Top bottom repay]: When feeding movement deviates in the vertical direction, and cause dislocation of graphics, compensation coefficient should be set to compensate feeding deviation. This parameter test needs only to be done for once.

[Left right repay]: When feeding movement deviates in the horizontal direction, and cause dislocation of graphics, compensation coefficient should be set to compensate feeding deviation. This parameter test needs only to be done for once.

Test method:

If the height of the breadth side is 600 mm, draw vertical lines to 600 mm, set segmentation reference to 590 mm and compensation coefficient to 0, click "Apply" button. Machine processing process is as follows: Laser head move and cut from 0 to 590 of Y direction, then it feeds 590 mm distance. Then Laser head returns to position of coordinates Y 580mm, and cut to coordinates Y 590 mm.

Check the test result.

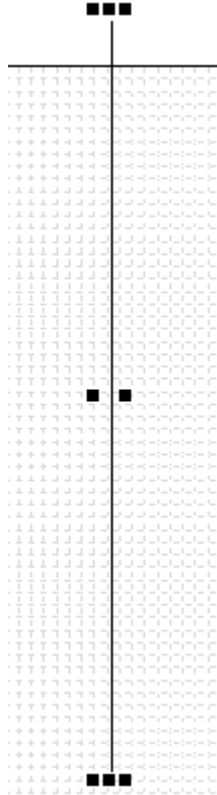

The long line below is 590 mm, the short line above is 10 mm, if the Top bottom direction offset is 0.2mm, then the top bottom repay is 0.2. If the left right direction offset is 0.3mm, then the left right repay is 0.3.

After the compensation coefficient is measured, every time a large file is segmented, modification of different segmentation reference doesn't require testing compensation efficient again. When the machine structure changes, or become aged after using for a long time, compensation coefficient could be tested again by using the same method.

1.6.6 Device type

There are two types of device: **general device** and **roller device**.

Two parameters such as **reference diameter** and **reference resolution** need to be set up while choosing **roller equipment**. After setting these two parameters, only roller diameter needs to be set as we replace the roller. The diameter of the roller and its

corresponding accuracy resolution could be input the same value as that of reference diameter and reference resolution.

Roller resolution Settings

- a) Click on the software interface - machine information - machine parameter - input password (tz0001) - and change the machine type to "Wheel equipment" in machine parameter page. Reference diameter and Reference resolution can be used as reference parameters.
- b) Reference parameter.
 - i. During roller processing course, as working piece of the different diameter needs to be replaced, the width and resolution of Y axis needs to be constantly modified. Control card provides a reference diameter and resolution.
 - ii. After setting the reference diameter and resolution, new working piece diameter needs to be set in the "Material diameter" parameter in machine parameter page. The resolution in "axis parameters" - "Y axis parameter" would be calculated automatically according to reference diameter and reference resolution, which means the diameter of the new working piece only need to be modified for once.
- c) Reference parameter modification
 - i. When changing the device type into wheel equipment type, there is a default value for reference diameter and reference resolution. The user needs to firstly measure reference diameter with a scale, then the default value or a value estimated by the user could be used as a reference resolution, 10 for example.
 - ii. Then draw a line on the current work piece such as 50, and measure the actual length, supposing it to be 55. Click the [>>] button beside the Reference resolution edit box and input Need length to 50 and fact length 55 according to the normal resolution modification process. Then click confirm and automatically calculate to the value 11 as reference resolution value for example.
- d) Change new working piece while working, input present working piece diameter in the "Material diameter". At this time, resolution value in the Y axis in the axis parameters page would calculate resolution and maximum traveling range of present working piece based on reference diameter and reference resolution.





Part 2 Panel operation instructions

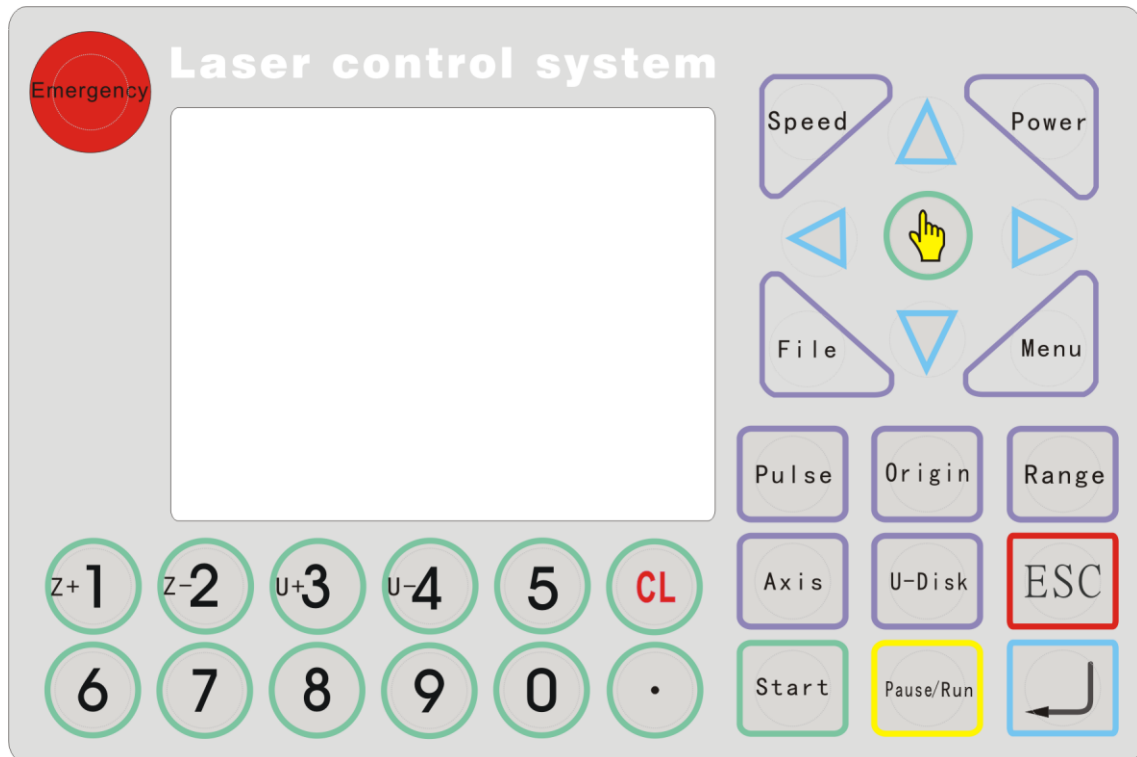





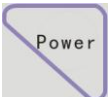





2.1 Introduction



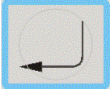

2.1.1 Operation panel

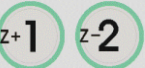

2.1.2 Key functions introduction

-  "Reset" key: no matter in what state, click this button and the machine would enter into a reset state, and then return to the set "anchor point".
-  Speed key: Set the working speed and travelling speed.
-  Power key: Enter into panel laser intensity setting interface.
-  Menu key: Click this button to enter the main menu.

5.  File key: Enter the memory file selection interface.
6.  U-Disk key: Enter U disk file selection interface.
7.  Range key: To preview range.
8.  Pulse key: It is used for testing. It will be lighted per time when press and is mainly used for testing light route adjustment.
9.  Origin key: Move XY to one position and then press origin key to set this current position as anchor point for process. About the Return point, if "mechanical origin" is selected, the machine will return to the mechanical origin after reset, the coordinates is (0, 0). "Set point" is selected, it returns to the position where set by origin key last time.
10.  Axis key: Access into single axis movement interface.
11.  Confirm key: A defining key, which indicates agreement of the current operation
12.  Exit key: A defining key, used to cancel the operation and return to the last interface.
13.  Start key: Press this key to start running the current file.
14.  Pause/Run key: Press this key in working mode to enter the suspension state. Repress to continue. In suspended state, after moving X or Y axis away, press this button again, it can automatically return to the stop position to continue working. When the machine is idle, press this button and the laser head will go to the anchor point.
15.   The number keys are used to change the selected area data. They can also be selected to choose the menu directly.
16.  The decimal point key is used to automatically align the button.

17.  The key is used for clearing impute value.
18.  Z axis movement keys are used for moving Z axis.
19.  U axis movement keys are used for moving U axis.
20.  Direction keys are used for moving X and Y axis. Up and down keys in other interface can also be used to move current selection upward and downward.
21.  Selection key: Standby interface is used to alter the speed of axis moving, other interface is used to modify parameters.

2.2 Main interface introduction

2.2.1 Starting up interface

Starting up interface is as follows:

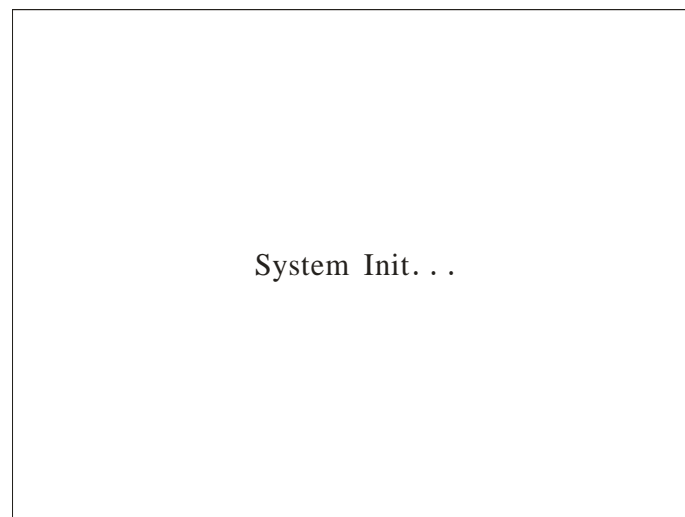

2.2.2 Standby interface

After initialization is completed, standby interface would appear. As shown in figure

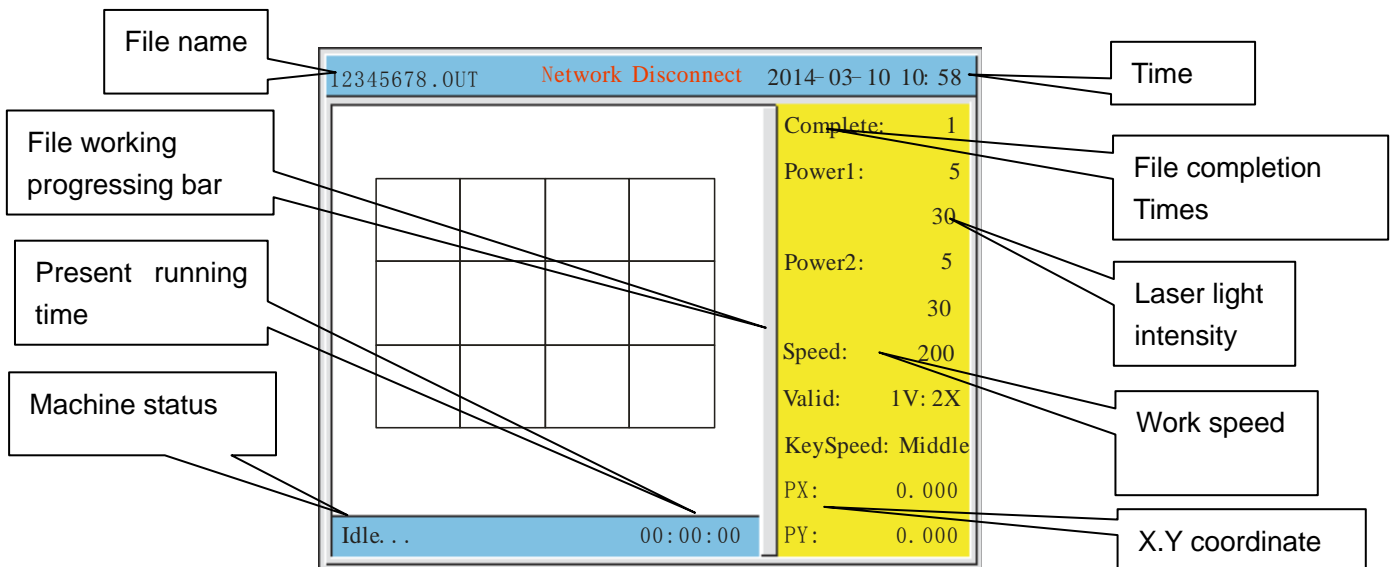

The top of the interface shows the file name, network status, the date and time. The white area shows the preview of the selected file. And the yellow area shows the complete times, default power, speed of the machine, the water protect status, the speed of key moving, and the position of axis x and axis y. And at the bottom left of the interface, it shows the machine status and the last working time.

The parameters are described below:

Network status: If connect the network, it'll show the IP address 196.168.0.100. Otherwise, it shows Network disconnect.

Complete: The complete times of the selected file.

Power1: The power of Laser 1. The above value is min power value. The following value is the max power value.

Power2: The power of Laser 2. The above value is min power value. The following value is the max power value.

Speed: It shows the work speed.



Valid: The water protection status. In the figure, the water protection is 1X: 2X, 1X means water protection 1 not connected, 2X means water protection 2 not connected. If connect, it'll show 1V:2V.

Key Speed: Manually move axis speed, can press the "Select" key to change the speed, there are "Fast", "Middle", "Slow".

PX, PY: The coordinate in the current place.

When there is no file selected, It displays the default power and speed. When selecting the file, it shows the power and speed in the first layer of the file. When processing, it shows the power and speed of the current processed layer.

When the machine is processing, if you want to modify the speed of the current layer, press the pause button, then press speed button, you can modify the speed of the current layer. In the same way, press power button to modify the min/max power. If machine is processing, press "Left/Right" button, can immediately reduce or increase the laser power. Press once, plus or minus 1%. Left for reduce, Right for increase. When changed the speed of power during working operation, after the completion of processing, it prompts whether to save the changes of the speed and power value.

In standby mode, press  to clear the completed number of selected file. If the focus length was set in laser parameter interface, press  to auto focus. If the firmware version is V.L010.16 or later which is for camera cutting machine, press the  button to start table cut function.

2.2.3 Speed setting interface

After initialization is completed press the "speed" button. As shown in figure:

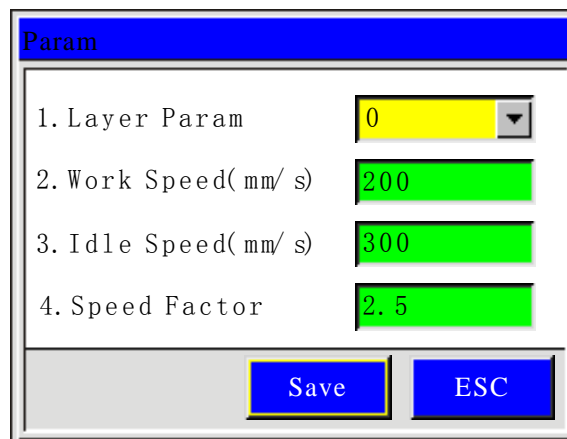

Param	
1. Layer Param	0
2. Work Speed(mm/ s)	200
3. Idle Speed(mm/ s)	300
4. Speed Factor	2.5

Save ESC

This shows the speed setting is effective when the speed of working file set as defaulted.

Layer Param: When one file is selected, press  button, to choose the layer number.

Work Speed: When one file is selected, it shows the work speed in current layer. Otherwise, it shows the system default speed value. The unit is mm/s.

Idle Speed: The default move speed when laser is off. When one file is selected, it shows the idle speed in current layer. Otherwise, it shows the system default speed value. The unit is mm/s.

Speed Factor: It is applied to improve the smoothness of movement. The range is 0.00-5.00. The smaller the factor, the slower of planned speed of lines in work file, and then the smoother of movement when turning corner. Normally it is set to 2. If the smoothness is high demanded, set the factor to less than 1.

2.2.4 Light intensity settings interface

After initialization is completed press the "frame" button. As shown in figure:

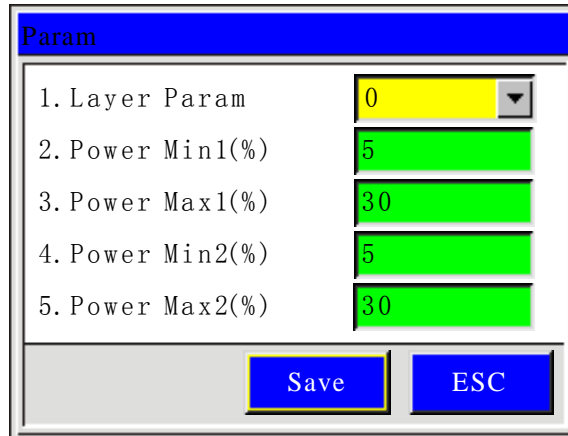

Layer Param: When one file is selected, press button, to choose the layer number.

Power Min: When stroking curves, this power intensity applied for line start and the corner of the curve .Or it applied for the top depth when gradient carving. The range is 0.00~100.00%.

Power Max: When stroking curves, this power intensity is applied as the work speed was reached. Or it applied for the bottom depth when gradient carving. The range is 0.00~100.00%.

Power Min1 is the min light power of LASER-1. Power Min1 is the max light power of LASER-1.It is the same as Power Min2 and Power Max2 of LASER-2. When no file is selected, the power value is the system default power value. When pulsing, the Power Max will be used.

2.2.5 Frame preview interface

After initialization is completed press the "frame" button. As shown in figure:

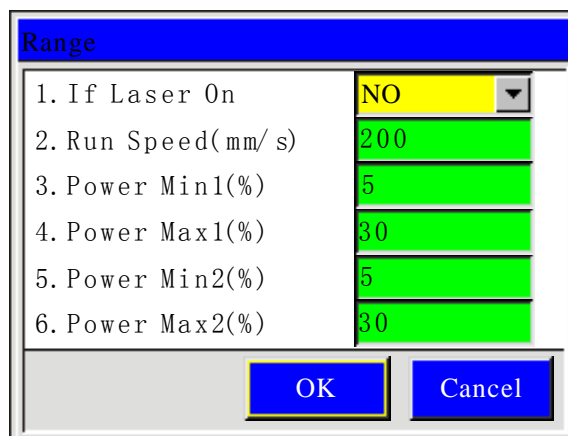

2.2.6 File selection interface

Press "Menu" key into the main menu, and select the Memory File button. Also can directly press "File" to enter, show as:

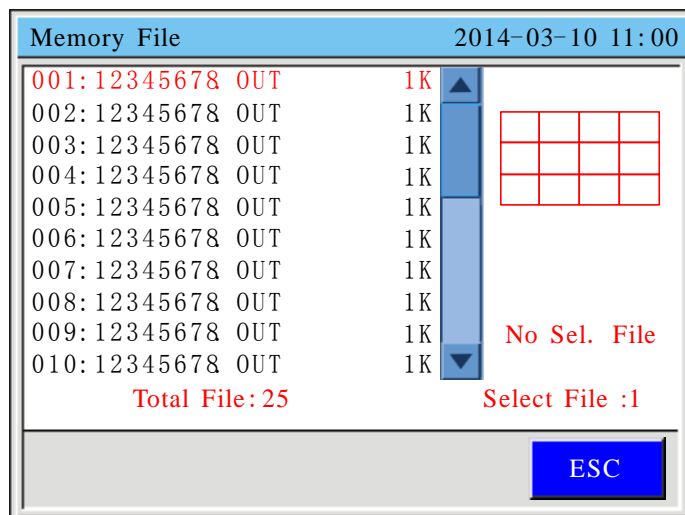

Press “Down/Up” to choose the file, press “Select” key to find the current file, press “ESC” to quit, press “Enter” to operate, show as:

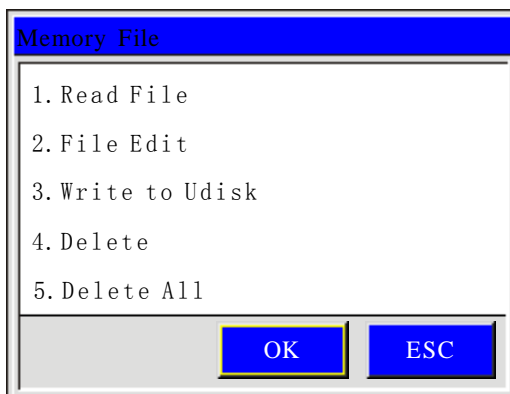

- **Reading File:** Select this file to work.
- **File Edit:** Edit the file parameters like speed and power.
- **Write to U Disk:** Copy the file into U disk.
- **Delete:** Delete the current file.
- **Delete all:** Delete all memory files.

2.2.7 File setting

After starting, press “Menu” into the main menu, choose the “File Set”, then press “Enter”, show as:

The image shows a dialog box titled "File Set" with a light blue header. Inside, there are four rows of settings, each with a label on the left and a dropdown menu on the right. The first row is "1. Save Type" with a yellow dropdown showing "General". The second row is "2. Save as CurSel" with a green dropdown showing "Yes". The third row is "3. Save and Execute" with a green dropdown showing "Yes". The fourth row is "4. File Work Mode" with a green dropdown showing "General". At the bottom of the dialog, there are two buttons: a yellow "Save" button and a blue "ESC" button.

Setting	Value
1. Save Type	General
2. Save as CurSel	Yes
3. Save and Execute	Yes
4. File Work Mode	General

Press "Up/Down" to choose the required operation, click "Select" key to change setting, press "Enter" to save the setting, click "ESC" to quit.

- **Save Type:** General or Temp Save. Temp Save means the received file is temporary file. It will be replaced by the new received file. General means the received files will be saved one by one, not be replaced.
- **Save as CurSel:** Once a file is finish downloading, it will be select as current file.
- **Save and Execute:** Once a file is finish downloading it will be executed.
- **File Work Mode:** General or Cyc.. It means all files will be executed one by one in cycle.

Part 3 Projection cutting

Note * in the following description, it is advised to use the projector with best resolution of 1280*768 and debugging on Windows 7 system. On Windows XP this debugging method is familiar with on Windows 7. According to the best resolution of the projector, it is to choose the best installation location in the process of installation and debugging.

3.1 Installation

1. Using the bracket securing the projector directly above the machine. Make the projector is perpendicular to the work table as possible! Maintain an optimal resolution of the projector case, according to their own machine working width adjust the installation height
2. After installing projector linked to a computer, and reset the machine to the mechanical origin, first determine whether the laser head within the valid projection range, and then set the resolution of the computer the same as projector. Specific methods of operation are as follows:
 - 1) Click the right mouse button on desk → properties → settings as shown in figure:

Change the appearance of your displays

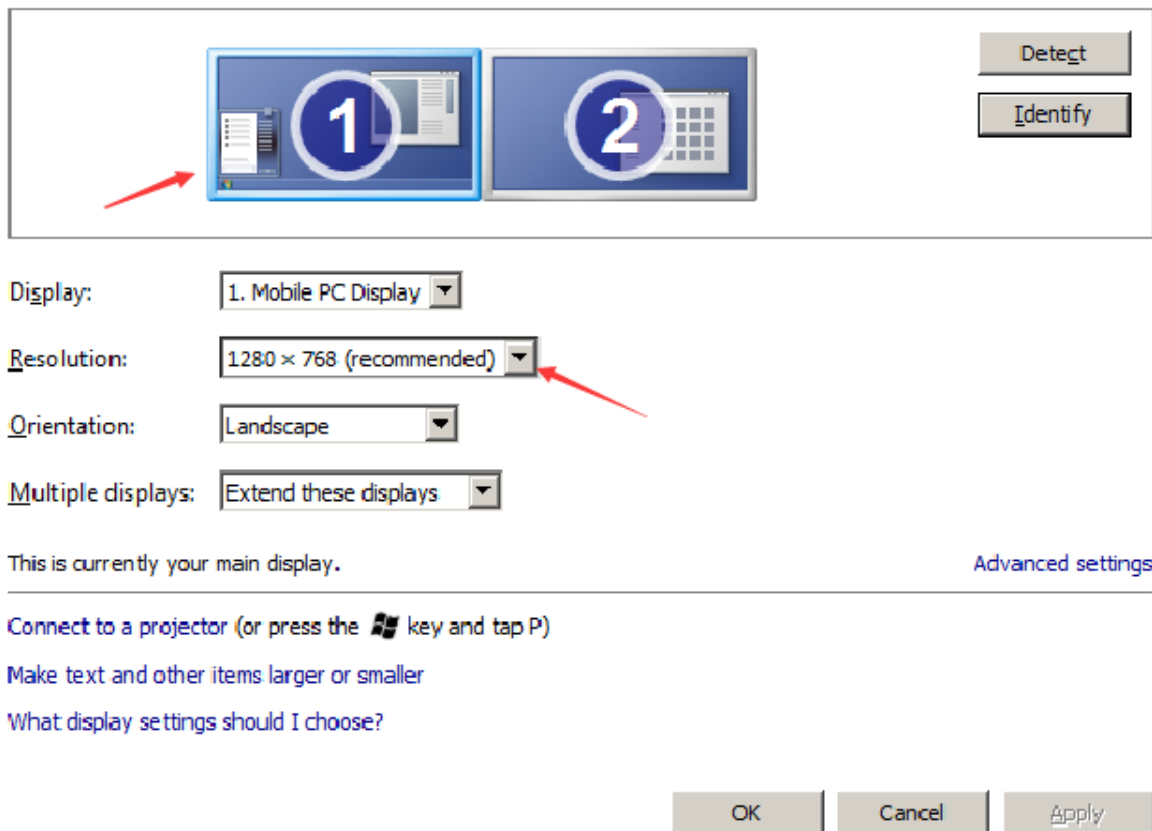

- 2) Select number 1 and view the screen resolution of your computer, and then select number 2 to see the resolution of the projector. And adjust the projector's resolution to the best. Then set the screen resolution of your computer the same as the projector. As shown in the figure.
- 3) Adjust the computer resolution and projector and select "Extend these displays", click "OK". The following figure:

Change the appearance of your displays

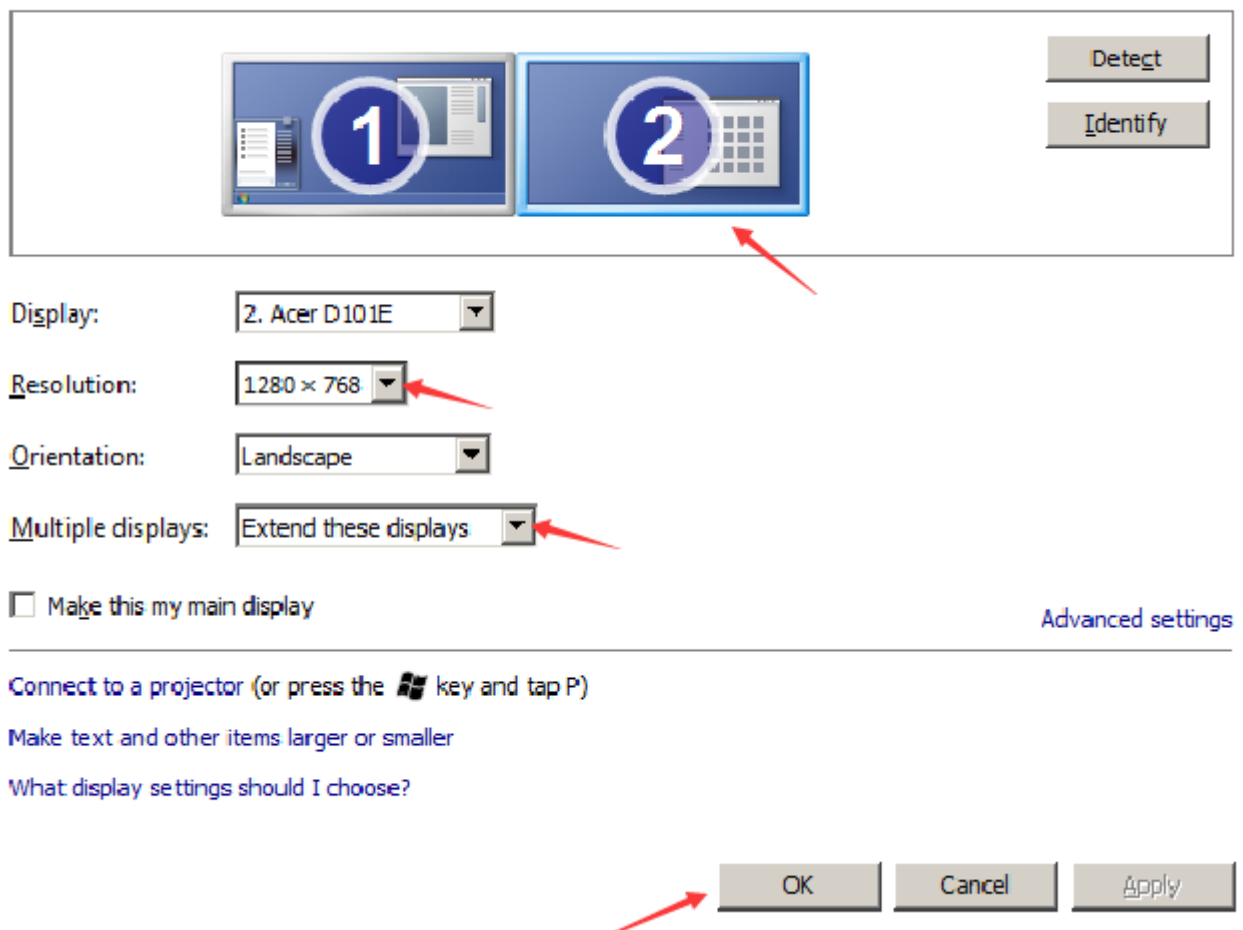

In the debugging process if the computer and the projector do not have the same resolution, you can select both to the nearest resolution.

3.2 Calibration

Following calibration is completed on the format for the 1600mm*1000mm machine.

1. Open laser software to make a 5-by-8 size 200*200 rectangle (full convergence), and let the machine cut it.
2. Insert the dongle on your computer, click on the software's "Module" option, select

"Projector calibration" as shown in Figure:

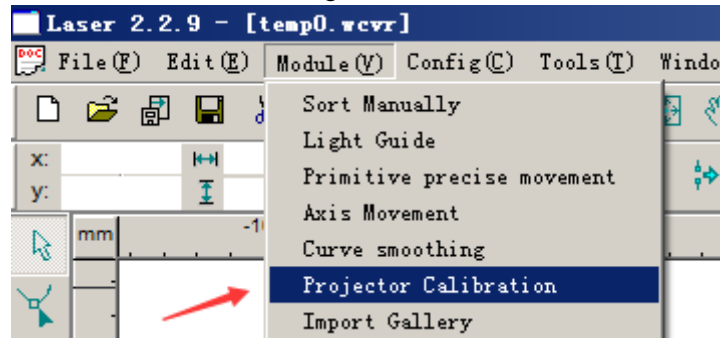

3. In right side of software the function set area will display a "Projector" page, turned to projector page, at first check the "Calibration Enable" box, then fill in regional wide (X) and regional height (Y), you also can directly click "Use frame" button then software will read maximum effective format of axis X/Y and calculate out the regional width and regional height.

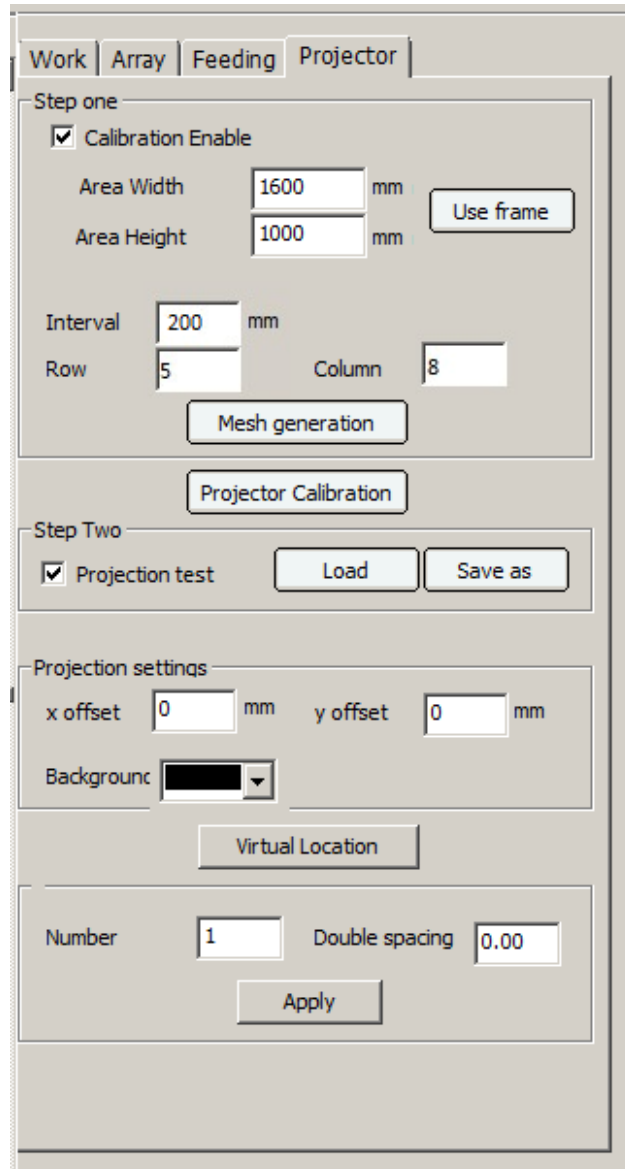

4. Click "Mesh generation" button. 4 rows and 7 columns 200mm rectangle will appear

in plot area, while the size of this rectangle is a projector with a 1:1 into the working area of the machine as shown in Figure:

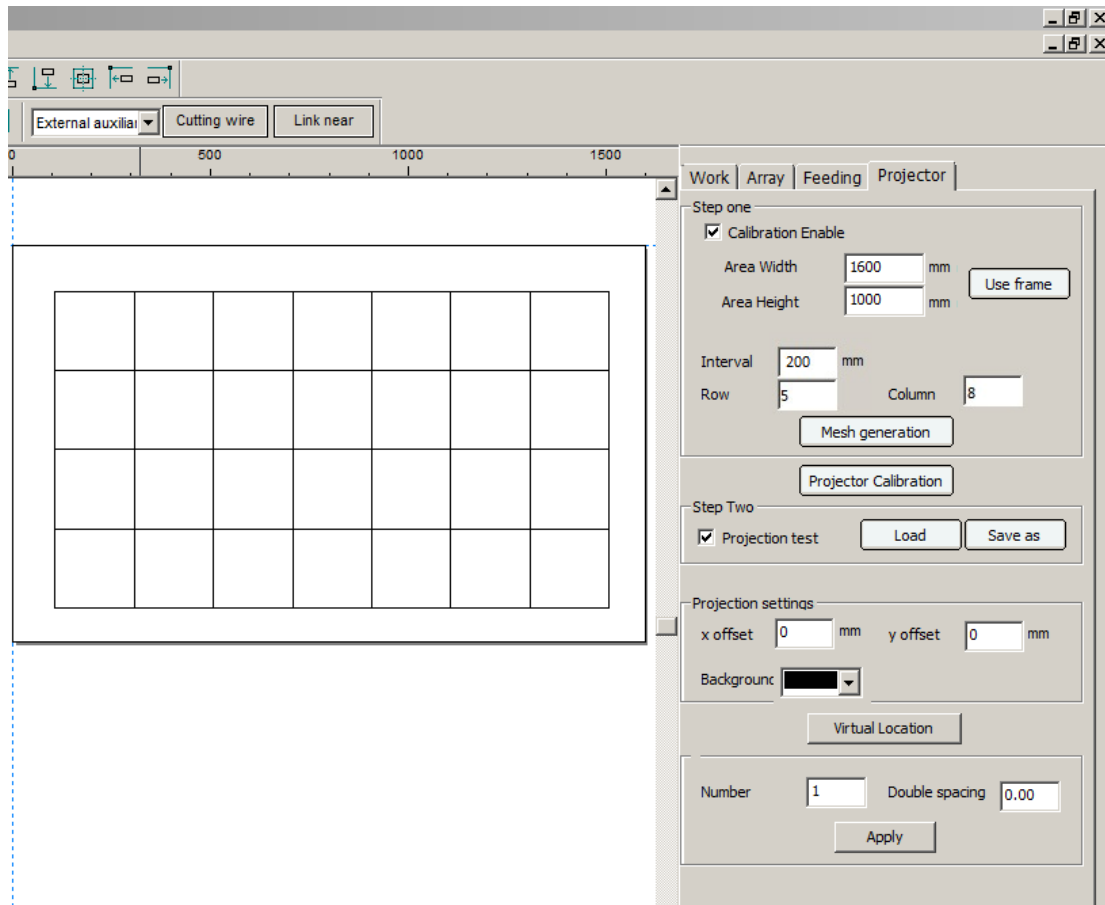

Note * since 1610 machine projector range cannot be taken to full size, so the figure should be 5 rows and 8 columns of the grid into 4 rows and 7 columns. But this does not affect the accuracy of calibration of the projector.

5. After grids are completed, go into work page to set the light intensity speed parameter, and then click on the download button to download file to cut grids. (Be sure processing set anchor is within valid range of the projection).
6. It will be seen that the cross circles are projected on the work table. Use the mouse left button to select it and hold on to drag, or double click the circle to use direction button on the keyboard to move it. Drag the circles to make the projected rectangle overlapping the cutting rectangle on the table. At last click "Projector Calibration" button. And enter the password tz0001, click on "OK". The entire calibration process is finished.
7. Next time open the software, the calibration parameter will be loaded directly, and does not need calibrating again, and you can also use the import parameters and export parameters to load/save the calibration parameters.
8. Projection test. After the check, grids will be projected onto the machine to test the projection parameters are correct.

3.3 Project setting

1. **X/Y offset:** refers to the projector used in the process will inevitably be some bias, the cast out graphic is a little different as before. It is not in the same place! Then we can give it an x, y offset to correct accuracy of graphic casted out by the projector! Use a ruler to measure actual offset values to set these offset parameter.
2. **Background color:** refers to the actual background color the projector cast out. When the cut materials color is familiar with the background colors, the two colors will blend together, it will not show out the graphic. In this case, you only need to select a different color in the background color. As shown in the figure:

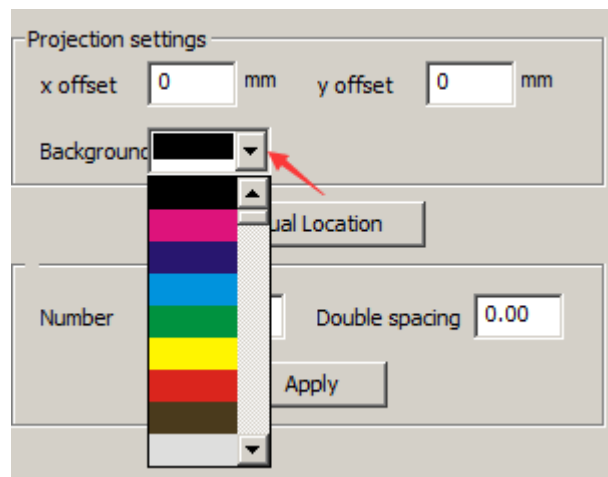

3. **Virtual location:** it means in the machine projected valid range the user can increase a temporary anchor point. After the machine work done, laser head will back to the location of the virtual position, it greatly shorten the distance of the laser head moving back and forth, make the laser work more easily and quickly. Setting methods should first set "Return point" to "None". Then move the laser head to where you want to set as a virtual location, and then click on the software "Virtual location".
4. **Number and interval:** when users need to use fixed double laser head cutting the same graphic you can use this feature. It only needs to fill in the corresponding parameter (Set the "Number" parameter to 2, and the "Double spacing" is the interval between the graphic for cutting by two laser head), click "Apply". It will generate a copy of the select graphics in the X direction. Change the copy object to another layer then prohibited output it. Now the graphics will be fit to cut by the fixed double laser head machine.

Questions and answer:

1. Check the "Calibration Enable" and found the following edited boxes are disabled. Check the control card is connected properly with your computer!
2. After calibration is complete, projection cannot normally found in the machine's workbench, or the projected object is not the same as the graphics in the software. Check the laser head is within the valid format into the projection range while doing calibration!

Part 4 Appendix

TL - 403C wiring diagram

Note: TL-403C is supplied by DC 5V 6A power. Please read this diagram carefully to avoid wiring wrong.

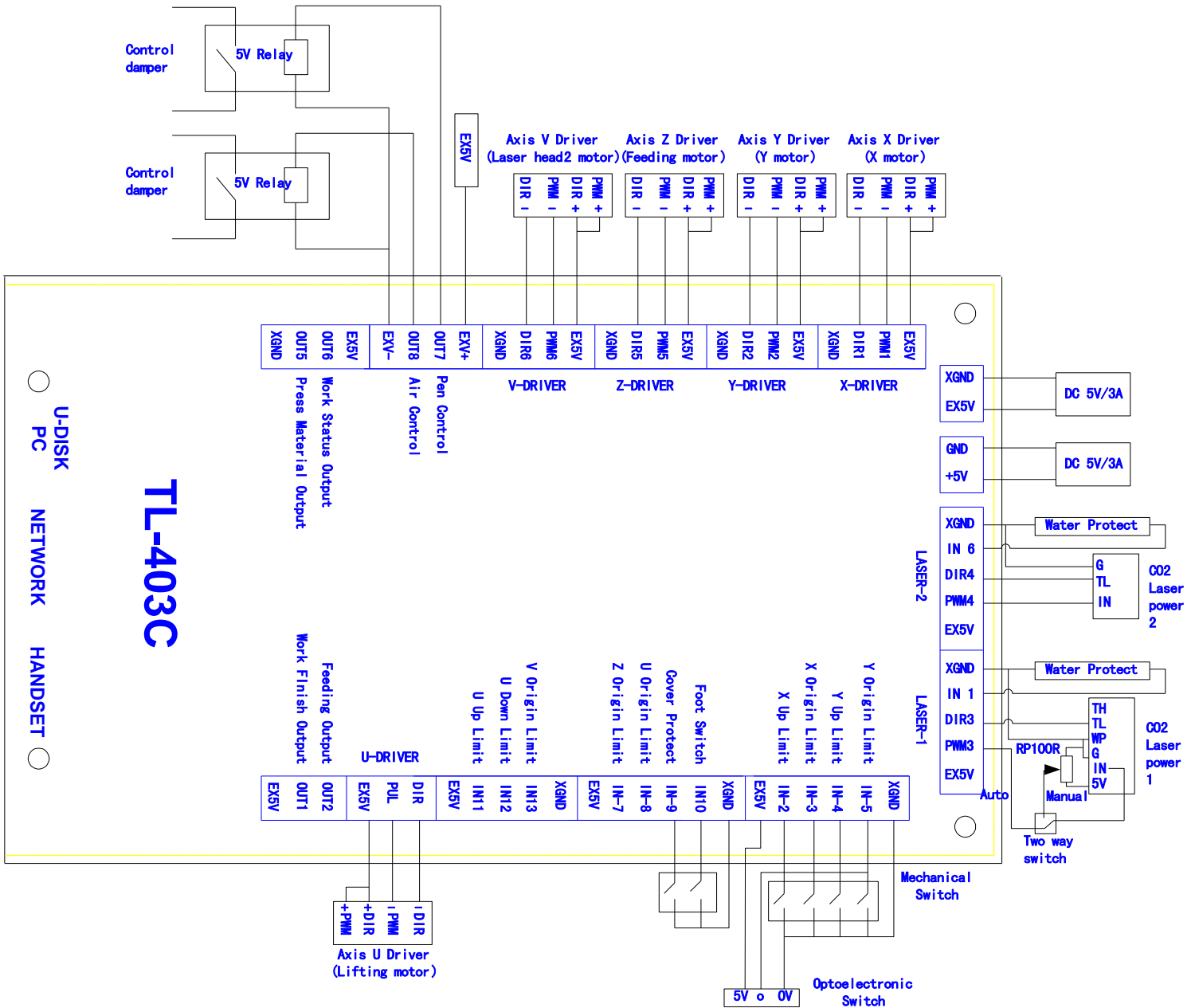

TL - 410C wiring diagram

Note: TL-410C is supplied by DC 24V 2A power. Please read this diagram carefully to avoid wiring wrong.

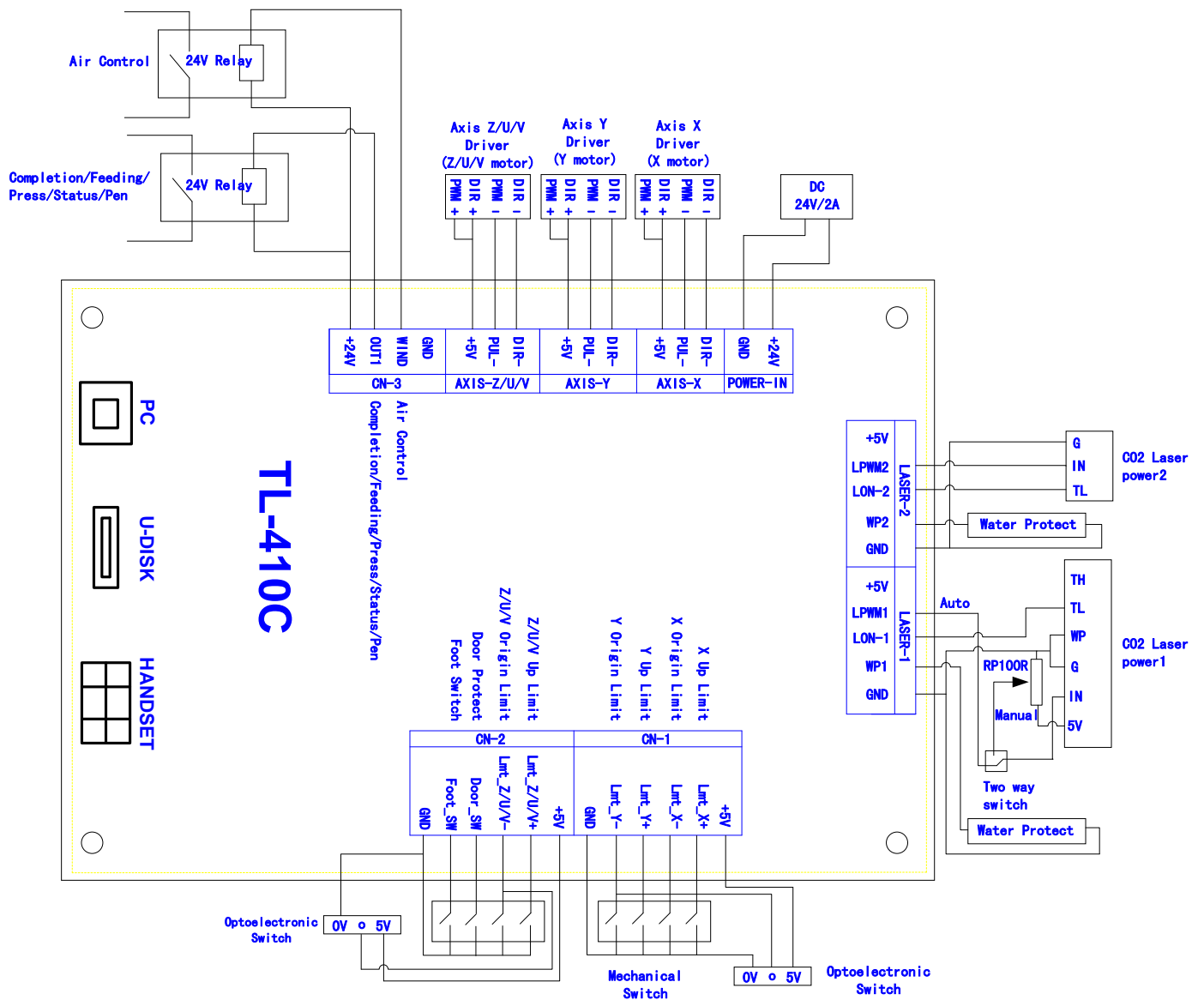

Installation dimension

1. Panel

The installation dimension of operation panel (the unit is MM):

Face:

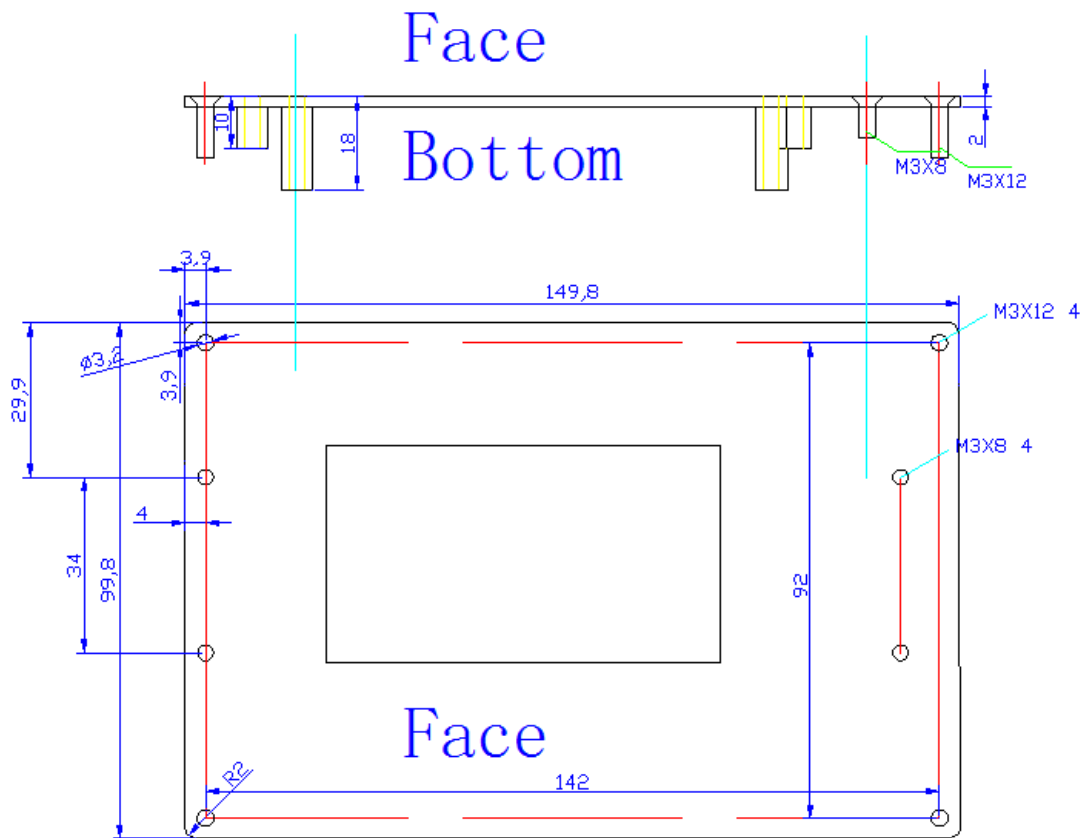

Bottom:

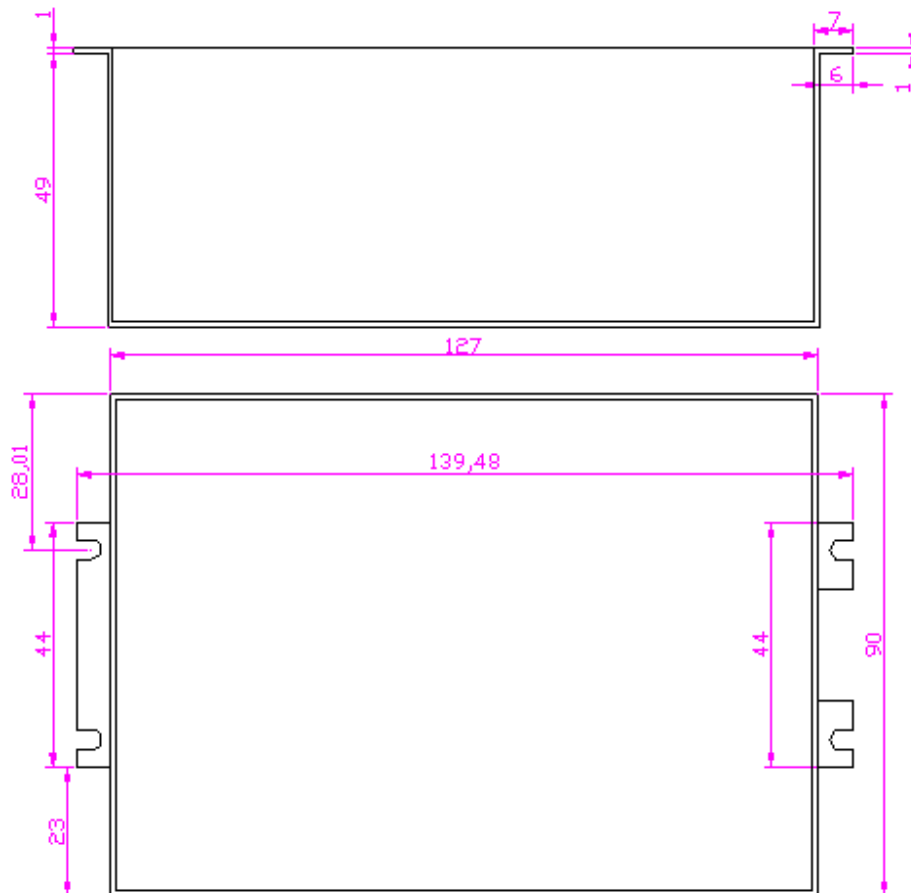

3. TL-410C mainboard

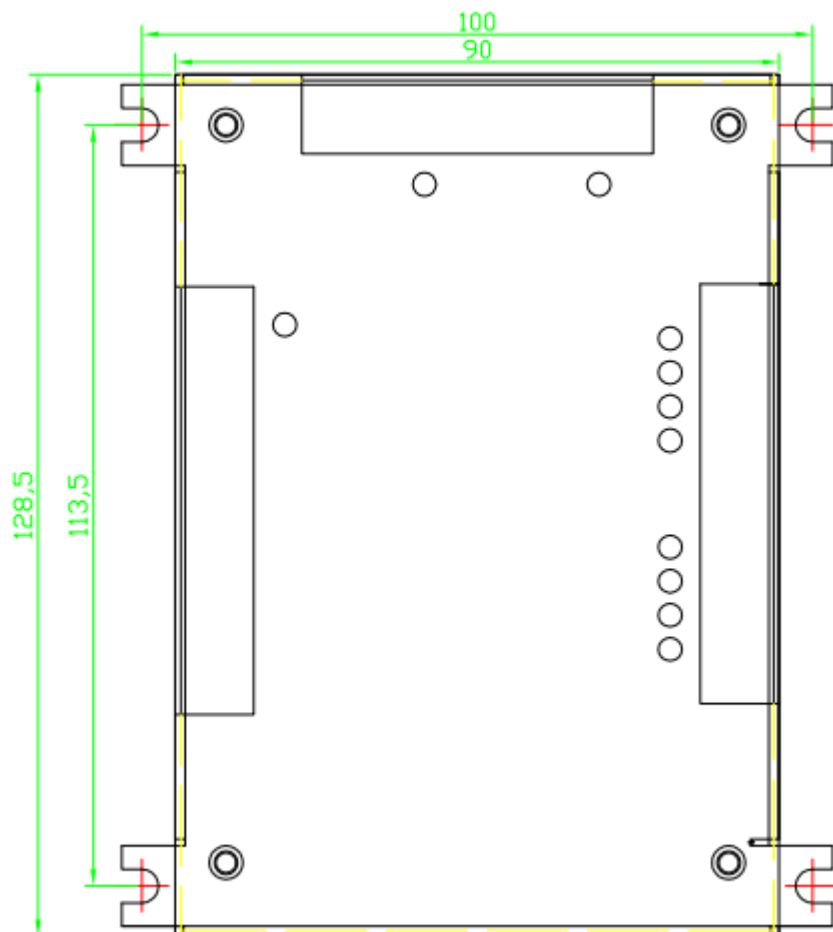
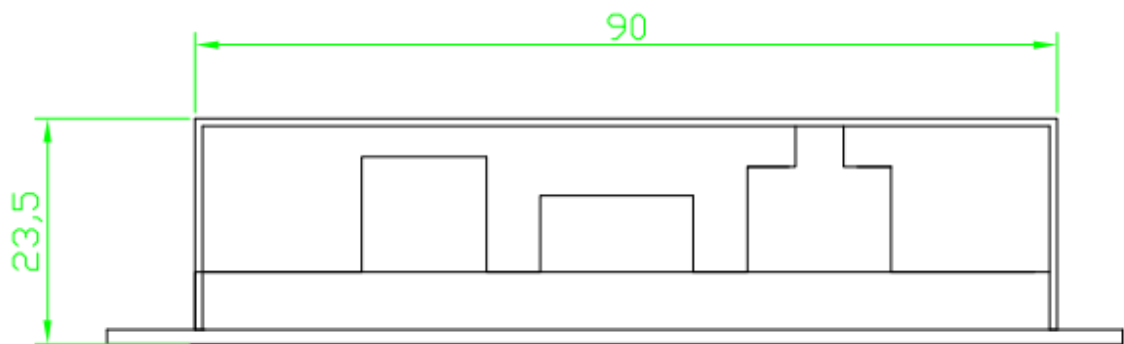

TL-410C Axis Z/U/V multiplexing and status signal

Output

1) Axis Z/U/V multiplexing

- a) Multiplexing axis is a share port for Z-Feeding, U-Lifting, V-double laser.
- b) To change the multiplexing function, select Menu / Integrate / Equipment Set /

Z/U/V Axis, then press the “Select” button  to change. Press “Enter” to save.

2) Status Signal

- a) Some output status is out from OUT1 port. It includes finish signal / work status / press / pen / feeding.
- b) To change the output signal function, select Menu / Integrate / Equipment Set /

OUT1, then press the “Select” button  to change. Press “Enter” to save.

Common and special function

1) Press up, down, left, right button and the laser head can be moved.

- a) Precise moving function can make the laser head accurately move its relative position.
- b) Click “laser” function and move, and the laser turns on during precise movement.

Application: When cutting some simple things, drawing could be omitted. It is useful to adjust axis resolution.

2) Press the Speed or Power button on the control panel to change the speed or power.

- a) If selected file is offered, power and speed of the file would be modified
- b) If there is no selected file, the default speed and power would be modified.

Application: there is no need to adjust power and speed on the computer software.

3) When the machine is in working mode, press the left and right button on the panel and working light intensity would be adjusted.

- a) Click the right button can increase light intensity by one percent.
- b) Click the left button can decrease light intensity by one percent.

Application: served as a potentiometer which can be directly checked and adjusted to the most appropriate light intensity.

4) Intelligent double head mutual shift.

Application:

- a) Without the need to artificially measure the distance between the two heads, the software will automatically assign distance according to pattern automatic switch light, thus saving the procedure of making layer to control the light switch.

- b) Leftover material can be added, when cutting the leftover material the light will be automatically switched on and off.

5) Present files processing times clearance.

Press the CL button on the panel to clean the current file processing times.

6) Layer processing suspension.

Delay after processing one layer could be set (in layer parameter settings interface, press > > button to set).

7) Work preview.

The graphics working trajectory and calculated working time of processing to can be previewed (the parameter for working time estimate should be precise enough for on-line reading).

8) Large file segmentation feeding.

This method is commonly used when the graphic length is greater than the range of axis Y. The files can be split automatically to complete processing under the support of feeding (some application need to be conducted by the machines with feeding shaft).

Common problems

1) Unable to download file.

- a) Open the computer device manager; plug USB cable to check whether the computer can find the COM. If the control card and the cables are in normal status, port number COM3 to COM9 will be displayed at the Port section. Such port number would suggest that there is something wrong with the line or control card, or the port may be connected to a wrong port, or the driver may not be installed. The port number can only be set between 3 and 9. If port number is displayed, click search in Laser software and the corresponding port would display.
- b) When using the Laser software, the type of machine will be examined (equipment information - type). Most machines are of the normal type, but if the machine is equipped with CCD camera shooting function, machine type should be changed to camera.

2) The “Out of range” message is displayed but the file breadth is enough for processing.

- a) Check whether the settings of “machine reset point” and “Pitch dot” in machine information setting page is wrong.
- b) In the case that software version doesn't match that of the control card, upgrade control card to the latest version.

3) Intelligent double-headed machine does not cut separately.

- a) Check the laser head type (Machine information - Machine parameters -

password (TZ0001) - Machine parameters – Laser way). For single belt, “Laser I” should be adopted, for double belts, select “Laser II”. And then, set a proper minimum distance between the two heads (the distance between the two laser heads).

- b) A virtual array should be used if the graphics is to be arrayed.

4) Control card firmware upgrading.

- a) Upgrading can be conducted through software (machine information - machine parameters - password (TZ0001) - statistics information - upgrading the firmware version (firmware version could be read first), and then find the firmware file to be upgraded and conduct upgrading.
- b) Upgrading can be conducted through U key.
 - i. Decompress the firmware file in U disk under the root directory.
 - ii. Insert U disk to the USB interface on the main board.
 - iii. Press the U disk on the control panel, make sure the machine can read U disk.
 - iv. Press the menu on the control panel, select “Sys. Info.” button, and select the “Sys. Update” button to upgrade,
 - v. Don't power off while upgrading. Do not perform other operations while upgrading. Generally speaking upgrading can be finished in about three minutes. After upgrading is completed, the current version number can be checked in the system version.

5) The process time and the effect cut in embroidered format file are not good.

- a) After selecting the graph, pressing smoothing button in the independent software, and the process time and effect would be improved.